

TEMP2000 - SERIES

TEMP2700



TEMP2500



COMMUNICATION MANUAL

Programmable Controller

※ This manual applies to TEMP2500 and TEMP2700.
The model stated the manual content is TEMP2500.

Contents

1. Safety Precautions	1
2. Communication Specifications	3
3. Communication Setting	4
4. Wiring for Communication	5
5. Communication Command	7
6. MODBUS Protocol	18
7. D-REGISTER Description	24
▪ D-REGISTER table	51

1. Safety Precautions

Thank you for purchasing TEMP2500, programmable controller.
This Communication Manual describes communication of the TEMP2500 controller.



SAFETY SYMBOL MARK

(A) Symbolizes 'Caution' and 'Warning'. The information with this symbol is especially important for preventing from user injury and protecting the product and system.



(1)Product : This symbol indicates an imminently hazardous situation which if not avoided, will result in serious injury or system damage.

(2)Communication Manual : This symbol indicates potential hazard that may cause personal injury by electrical shock.

(B) Symbolizes 'Protective Earth (PE) Terminal.'



This symbol indicates that the terminal must be connected to the Ground prior to operating.

(C) Symbolizes 'Supplementary Explanation.'



The information with this symbol describes additional explanation for features.

(D) Symbolizes 'Reference.'



This symbol indicates further information and page to refer.



Precautionary Remarks on this Communication Manual

- (A) This manual should be passed on the End- User and kept at a suitable place for easy review in time.
- (B) Read and understand this Communication Manual carefully before using the product.
- (C) This Communication Manual describes functions and features of the product in detail, and SAMWONTECH can not guarantee against over applications would suit a customer's particular purpose which is not described in this manual.
- (D) Unauthorized duplication and modification of this Communication Manual are strongly prohibited.
- (E) The contents of this manual may be modified without prior notice.
- (F) If any errors or omissions in this manual should come to the attention of the user, feel free to contact our sales representatives or our sales office.



Precautions for Safety and Unauthorized Modification

- (A) For protecting and ensuring the safety of this product and relevant system, all of the safety instructions and precautions should be well recognized and strictly observed by all users.
- (B) SAMWONTECH does not guarantee against damage resulting from unauthorized alteration, misuse, or abuse.
- (C) When using additional safety circuit or part such as Noise Filter to protect this product and relevant system, it is strongly required to install that to outside of this product. Additional installation and modification inside of this product are prohibited.
- (D) Do not try to disassemble, repair, or modify the product. It may become the cause of a trouble such as malfunction, electric shock, fire.
- (E) Contact our sales dept. for part replacement or consumables.
- (F) Keep the product away from water inflowing. This may become a critical cause of trouble.
- (G) External shock on the product may lead to damage and malfunction.



Limitation of Liability

- (A) SAMWONTECH does not guarantee or accept responsibility for this product other than the clauses stated in our warranty policy.
- (B) SAMWONTECH assumes no liability to any party for any loss or damage, direct or indirect, caused by the use or any unpredictable defect of the product.



Warranty Policy

- (A) Warranty term of this TEMP2500 is one year after delivery to the first purchaser for being free of defects in materials and faulty workmanship under the condition that the product has been applied according to this manual.
- (B) The repairing cost will be charged for defective product out of warranty period. This charge will be the actual cost estimated by SAMWONTECH.
- (C) Repairing cost may be charged even if within warranty period for following cases.
 - (1) Damage due to USER FAULT (Ex.: Product initialization by password loss).
 - (2) Damage due to natural disaster (Ex.: fire, flood).
 - (3) Damage due to additional removal and re-installation after the first one.
 - (4) Damage due to unauthorized disassembles, modification and alternation.
 - (5) Damage due to unexpected power failure caused unstable power supply.
 - (6) Others
- (D) If any A/S is required, feel free to contact our sales office or a representative.

2. Communication Specification

The TEMP2500 controller provides Half-Duplex method support on RS232C and RS485 communication interface.

- RS232C interface supports 1:1 direct communication between host computer on network system and TEMP2500.
- RS485 interface supports to connect upper level network system with up to 31 slave TEMP2500 controller.

■ Parameters for communication setting

Parameter	Range	Description
PROTOCOL	PCLINK	Default protocol
	PCLINK+SUM	Default protocol + CheckSum
	MODBUS ASC	MODBUS ASCII
	MODBUS RTU	MODBUS RTU
SPEED (BPS)	9600	9600 bps
	19200	19200 bps
	38400	38400 bps
	57600	57600 bps
	115200	115200 bps
PARITY	NONE	None Parity
	EVEN	Even Parity
	ODD	Odd Parity
STOP BIT	1	1 bit
	2	2 bits
DATA LENGTH	7	7 bits
	8	8 bits
ADDRESS	1~99	Address
RESPONSE TIME	0~10	RESPONSE TIME(=PROCESS TIME+SPONSE TIME*10msec)
SYNC MASTER	OFF	OFF
	ON	ON

■ Factory default value

• PROTOCOL	PCLINK+SUM(PCLINK+CheckSum)
• BPS	9600 bps
• PARITY	NONE
• STOP BIT	1 (1 bit)
• DATA LENGTH	8 (8 bits)
• ADDRESS	1
• RESPONSE TIME	0 (PROCESS TIME+10msec)
• SYNC MASTER	OFF

3. Communication setting

TEMP2500 provides flexible communication interface RS232C or RS485 from Control Unit directly.

- ▶ After detaching BACK COVER from Control Unit shown as [Figure-1], communication interface between RS232C and RS485 can be selected with socket and pin-header on power board of Control Board.
- ▶ It is recommended to use tool like tweezers for setting socket to pin-header correctly.

☞ Make sure setup completed correctly.

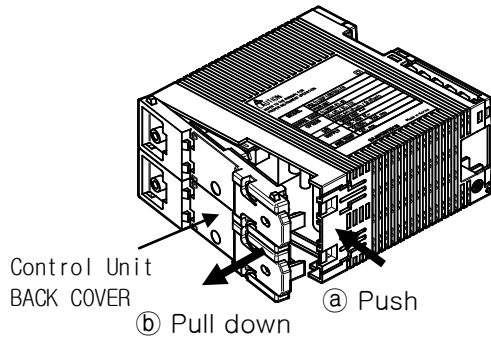

[Figure-1] Control Unit

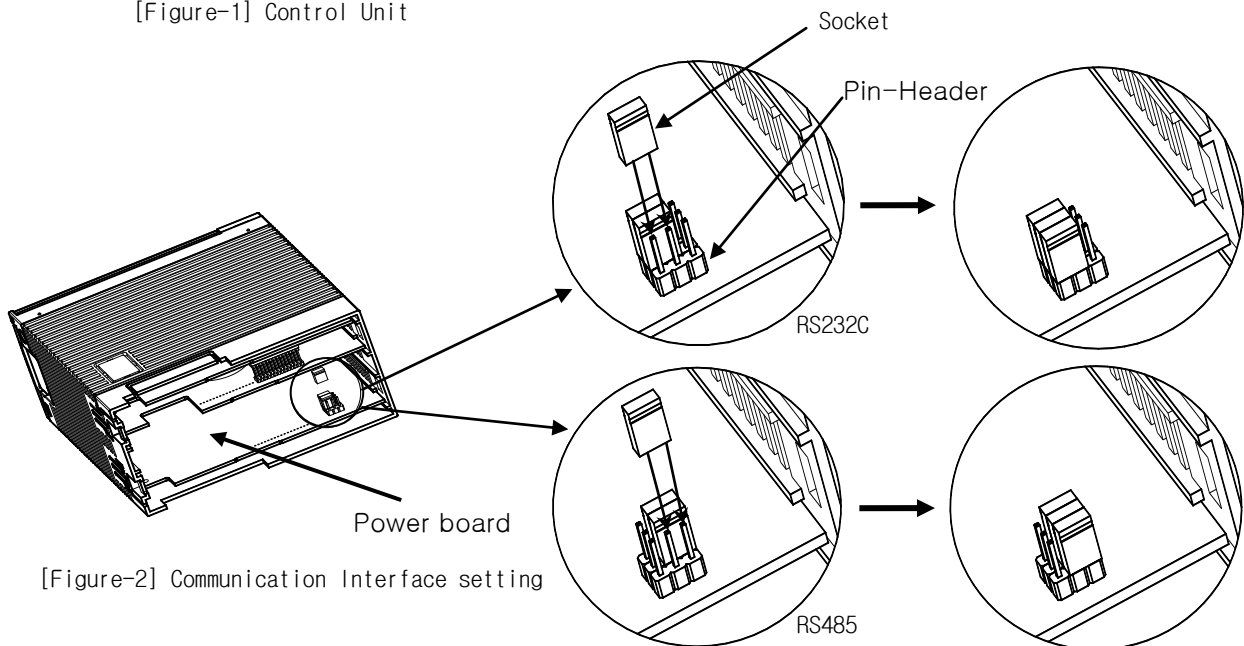

[Figure-2] Communication Interface setting



- ▶ Do not disassemble Power board from Control Unit case during setting comm. interface.
- ▶ It is recommended to use tool like tweezers for setting comm. interface.
- ▶ Make sure setup completed correctly.

4. Wiring for Communication

Connector wiring between TEMP2500 and network system depends on communication interface setting (RS232C/RS485).

Modular Connector Pin-Mapping for COM2 port

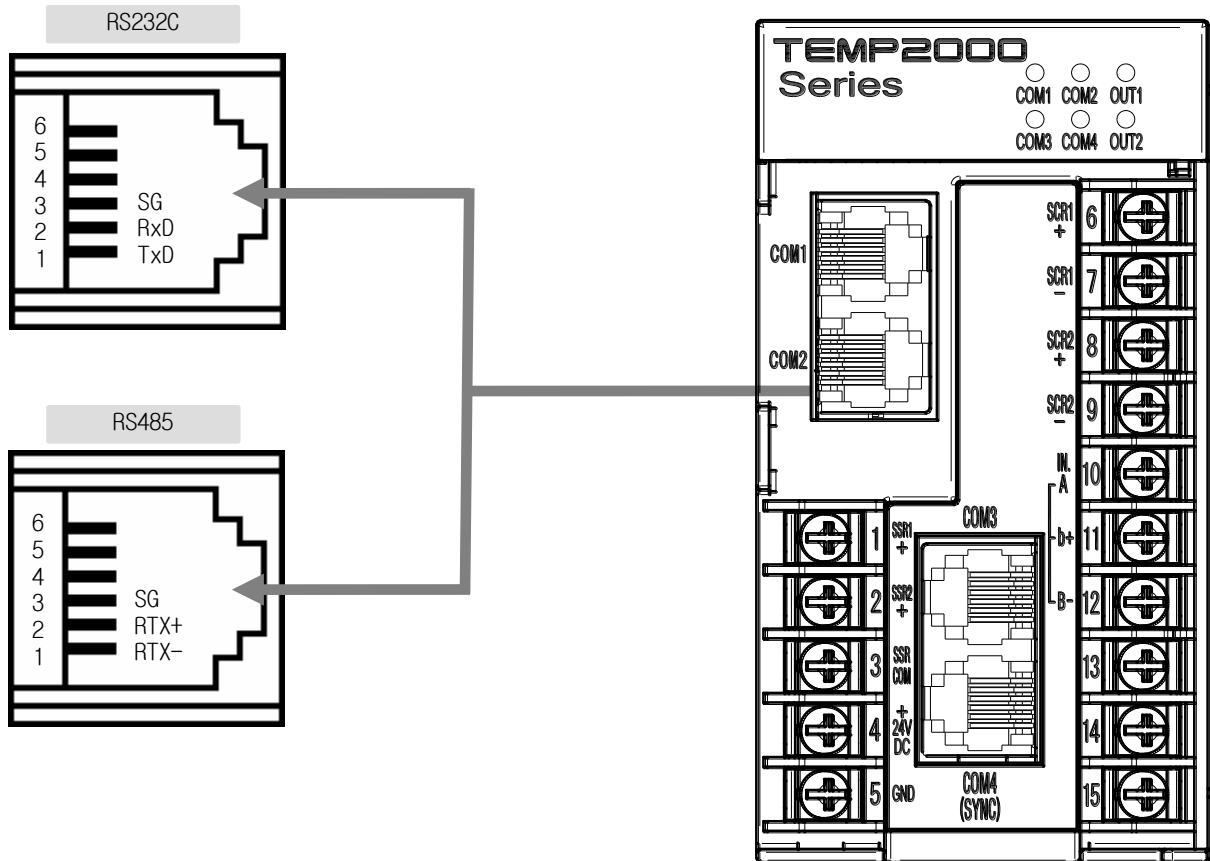

Description of Modular Connector Pin-Mapping for COM2 port

PIN no.	RS232C		RS485	
	Signal	Symbol	Signal	Symbol
1	Transmit Data	TxD	Receive/Transmit Data -	RTX-
2	Receive Data	RxD	Receive/Transmit Data +	RTX+
3	Signal Ground	SG	Signal Ground	SG
4	-	-	-	-
5	-	-	-	-
6	-	-	-	-

6 Pin connector wiring for RS232C interface

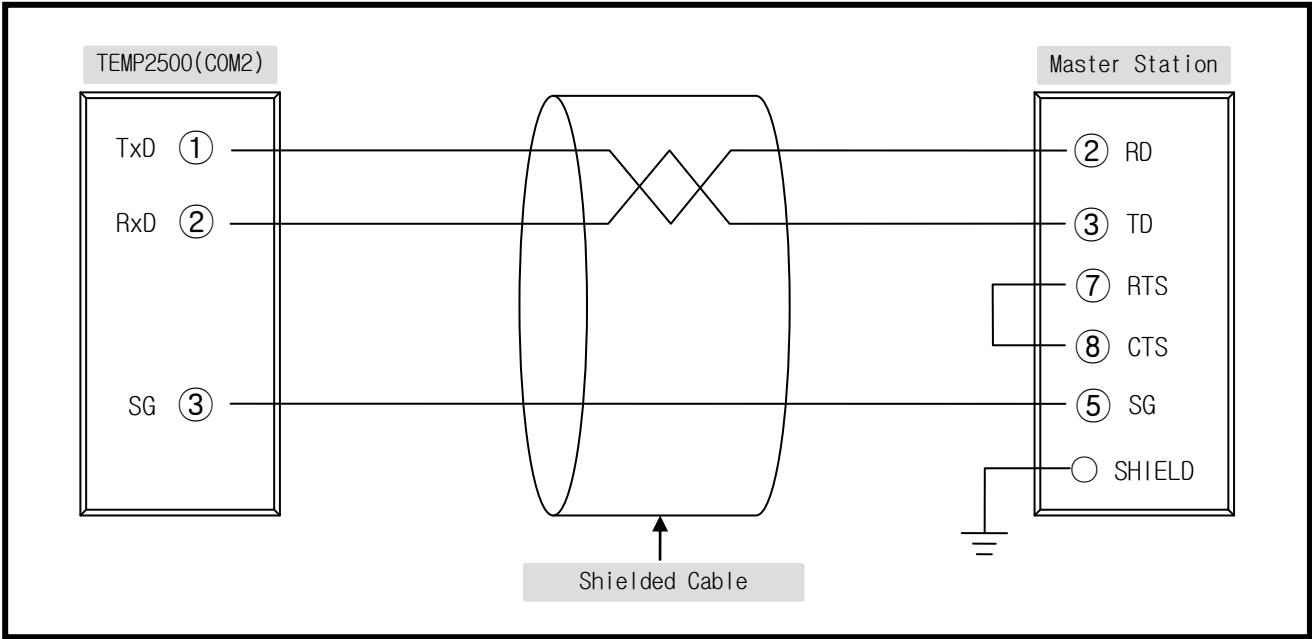

6 Pin connector wiring for RS485 interface

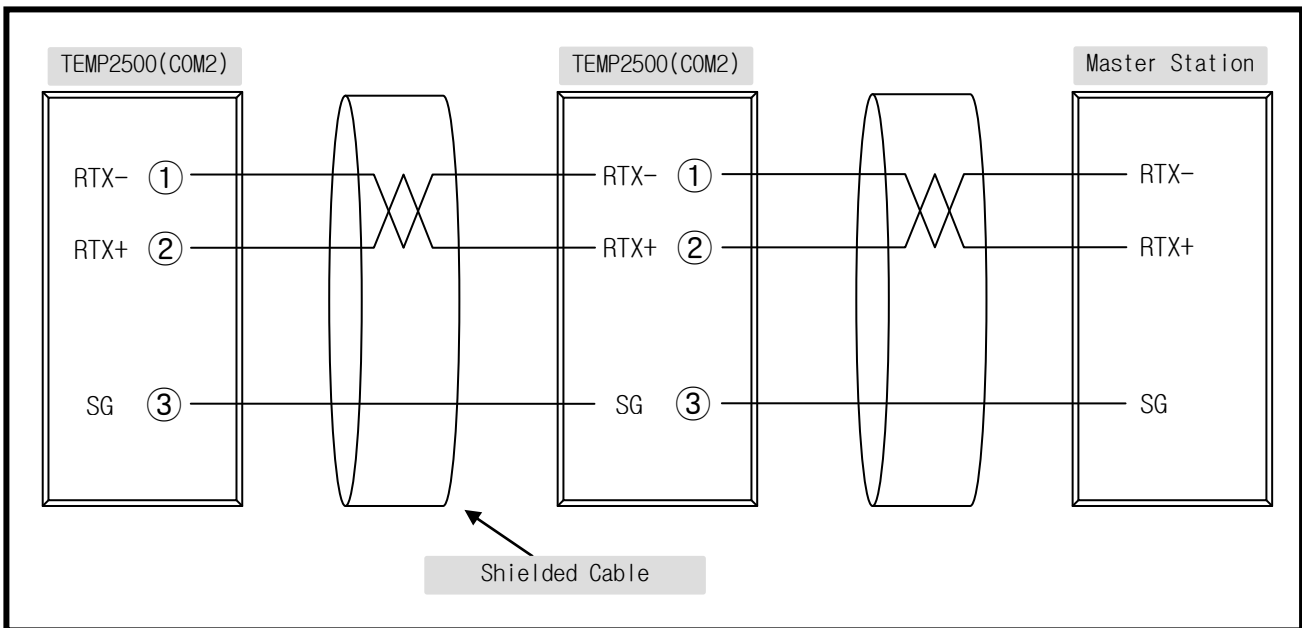

☞ Up to 31 slave TEMP2500 controllers can be connected to a master device by multi-drop networking.

☞ Make sure to install 200Ω (1/4W) resistor on Last Leg at both end of terminal Slave and Master(PC, PLC).

5. Communication Command

5.1 The Frame Structure of standard protocol

The frame structure of protocol transmitting upper-level network system to TEMP2500

①	②	③	④	⑤	⑥	⑦	⑧
STX	Address	Command	,	Data	SUM	CR	LF

① Protocol Header

The beginning of communication command with STX (Start of Text), ASCII string with 0x02.

② Slave TEMP2500 Address

Slave unit address of TEMP2500.

③ Command

Function Command for communication. (Refer to 5.2 ~ 5.10).

④ Delimiter

Symbolize to separate Command and Data by Comma. (',')

⑤ Data

Formal text strings regulated by communication command rule.

⑥ Check Sum

- 'SUM' protocol is a more sophisticated one which includes Check Sum as an error check.
- Check Sum is calculated as following.

- 1) Add the ASCII code of characters from the character next to STX one by one up to the character prior to SUM
- 2) Represent the lowest one byte of the sum as a hexadecimal notation (2 characters).

⑦, ⑧ Protocol Tail

ASCII code to close communication command by indicating CR(0x0D) and LF(0x0A).

■ Example for SUM

◆ Example

To read the consecutively D-Register from D0001 (NPV) to D0005 (MVOUT)

- Rrequest : [stx]01RSD,05,0001[cr][lf]
- Rrequest (with CheckSum) : [stx]01RSD,05,0001**C8**[cr][lf]

☞ As shown below, hexa decimal value adding each text at 01RSD,05,0001 by ASCII code is 2C8, and lower digit 2 characters **C8** will be used for CheckSum.

Text	0	1	R	S	D	,	0	5	,	0	0	0	1
Ascii value	30	31	52	53	44	2C	30	35	2C	30	30	30	31



■ ASCII Table

High Low	0	1	2	3	4	5	6	7
0	NUL	DLE	SPACE	0	@	P	`	p
1	SOH	DC1	!	1	A	Q	a	q
2	STX	DC2	"	2	B	R	b	r
3	ETX	DC3	#	3	C	S	c	s
4	EOT	DC4	\$	4	D	T	d	t
5	ENQ	NAK	%	5	E	U	e	u
6	ACK	SYN	&	6	F	V	f	v
7	BEL	ETB	'	7	G	W	g	w
8	BS	CAN	(8	H	X	h	x
9	HT	EM)	9	I	Y	i	y
A	LF	SUB	*	:	J	Z	j	z
B	VT	ESC	+	;	K	[k	{
C	FF	FS	,	<	L	¥	l	
D	CR	GS	-	=	M]	m	}
E	SO	RS	.	>	N	^	n	~
F	SI	US	/	?	O	_	o	DEL

5.2 Type of Communication Command

Two types of commands are provided on TEMP2500. One is general READ/WRITE command to read and write information on D-Register, and the other is Reference command to read self-information of TEMP2500.

■ Reference Command

Command	Description
AMI	Displays model name and Version-Revision of TEMP2500

■ Read/Write Command

Command	Description
RSD	Read data in consecutive D-Register in sequence (Read)
RRD	Read data in arbitrary single D-Register (Read)
WSD	Write data in consecutive D-Register in sequence (Write)
WRD	Write data in arbitrary single D-Register (Write)
STD	Register arbitrary single address to monitor (D-Register Monitoring Set)
CLD	Read data in address registered by STD command (D-Register Monitoring Call)

☞ Each Command can read or write up to 64 D-Register and all of the SED/CLD data will be reset by power OFF, so the data should be registered again.

5.3 ERROR Response

When an Error occurs during communication, TEMP2500 transmits a frame as following.

bytes	1	2	2	2	2	1	1
Frame	STX	Address	NG	Error Code	SUM	CR	LF

▣ Description of Error Code

Error Code	Description	Remarks
01	Invalid Command setting	
02	Invalid D-Register setting	
04	Data Setting Error	Invalid text data input (Available 0~9, A~F : hexadecimals)
08	Invalid Format configuration	<ul style="list-style-type: none"> ▪ Different command format with designated ▪ Differnet number of setting with designated
11	Checksum Error	
12	Monitoring Command Error	No setup Monitoring Command
00	Other Errors	

5.4 RSD Command

RSD Command is used to read data in a part of D-Register by consecutive address in sequence.

Request Message Frame

bytes	1	2	3	1	2	1	4	2	1	1
Frame	STX	Address	RSD	,	Count Number	,	D-Reg.	SUM	CR	LF

Response Message Frame

bytes	1	2	3	1	2	1	4	1	...
Frame	STX	Address	RSD	,	OK	,	Data - 1	,	...

1	4	2	1	1
,	Data - n	SUM	CR	LF

- Count Number : 1 ~ 64
- Data : Hexa-decimal 16bit string 4 character with no decimal point

Example

To read the D-Register **FROM** D0001 (NPV) **TO** D0003 (NSP)

- Request : [stx]01RSD,03,0001[cr][lf]
- Request (with CheckSum) : [stx]01RSD,03,0001C6[cr][lf]
([stx] = 0x02, [cr] = 0x0d, [lf] = 0x0a)

Response data will be same as below, when 50.0 of D0001 (NPV) and 30.0 of D0003 (NSP)

- Response : [stx]01RSD,OK,01F4,0000,012C[cr][lf]
- Response (with CheckSum) : [stx]01RSD,OK,01F4,0000,012C05[cr][lf]

※ Converting procedure 4digits hexadecimal response to decimal value.

- ① Radix conversion (Decimalize) : 01F4(hexadecimal) → 500(decimal)
- ② Multiply factor (decimal point) : 500 * 0.1 → 50.0

5.5 RRD Command

RRD Command is used to read data in arbitrary single D-Register.

Request Message Frame

bytes	1	2	3	1	2	1	4	1	...
Frame	STX	Address	RRD	,	Count Number	,	D-Reg.- 1	,	...

1	4	2	1	1
,	D-Reg.- n	SUM	CR	LF

Response Message Frame

bytes	1	2	3	1	2	1	4	1	...
Frame	STX	Address	RRD	,	OK	,	Data - 1	,	...

1	4	2	1	1
,	Data - n	SUM	CR	LF

- Count Number : 1 ~ 64
- Data : Hexa-decimal 16bit string 4 character with no decimal point

Example

To read the D-Register D0001 (NPV) and D0003 (NSP)

- Request : [stx]01RRD,02,0001,0003[cr][lf]
- Request (with CheckSum) : [stx]01RRD,02,0001,0003B3[cr][lf]

Response data will be same as below, when 50.0 of D0001 (NPV) and 30.0 of D0003 (NSP)

- Response : [stx]01RRD,OK,01F4,012C[cr][lf]
- Response (with CheckSum) : [stx]01RRD,OK,01F4,012C18[cr][lf]

5.6 WSD Command

WSD command is used to write data to a part of D-Register by consecutive address in sequence.

Request Message Frame

bytes	1	2	3	1	2	1	4	1	4
Frame	STX	Address	WSD	,	Count Number	,	D-Reg.	,	Data - 1

1	...	1	4	2	1	1
,	...	,	Data - n	SUM	CR	LF

Response Message Frame

bytes	1	2	3	1	2	2	1	1
Frame	STX	Address	WSD	,	OK	SUM	CR	LF

- Count Number : 1 ~ 64
- Data : Hexa-decimal 16bit string 4 character with no decimal point

Example

To write data to the D-Register **FROM** D0115 (TEMP.OP_H) **TO** D0116 (TEMP.OP_M) on FIX mode operation

- Setting TEMP.OP_H : 99Hour → Hexadecimalize (0x0063)
- Setting TEMP.OP_M : 50Min → Hexadecimalize (0x0032)
- Request : [stx]01WSD,02,0115,0063,0032[cr][lf]
- Request(with CheckSum) : [stx]01WSD,02,0115,0063,0032B6[cr][lf]

5.7 WRD Command

WRD Command is used to write data in arbitrary single D-Register.

Request Message Frame

bytes	1	2	3	1	2	1	4	1	4
Frame	STX	Address	WRD	,	Count Number	,	D-Reg. - 1	,	Data - 1

1	...	1	4	1	4	2	1	1
,	...	,	D-Reg. - n	,	Data - n	SUM	CR	LF

Response Message Frame

bytes	1	2	3	1	2	2	1	1
Frame	STX	Address	WRD	,	OK	SUM	CR	LF

- Count Number : 1 ~ 64
- Data : Hexa-decimal 16bit string 4 character with no decimal point

◆ Example

To write 50.0 °C into the D0104(TSP) and 0.5 °C into the D0110(SLOPE) on FIX mode operation.

- Setting TSP : 50.0 °C → Remove decimal point (500) → Hexadecimalize (0x01F4)
- Setting SLOPE : 0.5 °C → Remove decimal point (5) → Hexadecimalize (0x0005)
- Request : [stx]01WRD,02,0104,01F4,0110,0005[cr][lf]
- Request (with CheckSum) : [stx]01WRD,02,0104,01F4,0110,0005B3[cr][lf]

5.8 STD Command

STD Command is used to list the D-Registers that is necessary to monitor frequently.

Request Message Frame

bytes	1	2	3	1	2	1	4	1	4
Frame	STX	Address	STD	,	Count Number	,	D-Reg. - 1	,	D-Reg. - 2

1	...	1	4	1	4	2	1	1
,	...	,	D-Reg. - (n-1)	,	D-Reg. - n	SUM	CR	LF

Response Message Frame

bytes	1	2	3	1	2	2	1	1
Frame	STX	Address	STD	,	OK	SUM	CR	LF

- Count Number : 1 ~ 64

Example

To register D0001 (NPV), D0003 (NSP) and D0005 (MVOUT)

- Request : [stx]01STD,03,0001,0003,0005 [cr][lf]
- Request (with CheckSum) : [stx]01STD,03,0001,0003,0005A8[cr][lf]

5.9 CLD Command

CLD Command is used to read data in the address which had been registered by STD command.

Request Message Frame

bytes	1	2	3	2	1	1
Frame	STX	Address	CLD	SUM	CR	LF

Response Message Frame

byte 수	1	2	3	1	2	1	4	1	4
Frame	STX	Address	CLD	,	OK	,	Data - 1	,	Data - 2

1	...	1	4	1	4	2	1	1
,	...	,	Data - (n-1)	,	Data - n	SUM	CR	LF

- Count Number : 1 ~ 64

Example

- Request : [stx]01CLD[cr][lf]
- Request (with CheckSum) : [stx]01CLD34[cr][lf]

5.10 AMI Command

AMI Command is used to get the controller own-information.

Request Message Frame

bytes	1	2	3	2	1	1
Frame	STX	Address	AMI	SUM	CR	LF

Response Message Frame

bytes	1	2	3	1	2	1
Frame	STX	Address	AMI	,	OK	,

9	2	7	2	1	1
Model Name	SPACE	Version-Revision	SUM	CR	LF

Example

To confirm controller own information

- Request : [STX]01AMI[CR][LF]
- Request (with CheckSum) : [STX]01AMI38[CR][LF]

- Response : [STX]01AMI,OK,TEMP-2000[sp][sp]V00-R00[CR][LF]
- Response (with CheckSum) : [stx]01AMI,OK,TEMP-2000[sp][sp]V00-R0024[cr][lf]

6. MODBUS Protocol

6.1 The Frame Structure of MODBUS protocol

▣ Data Format

Item	ASCII	RTU
Protocol Header	:(Colon)	N/A
Protocol Tail	[CR][LF]	N/A
Data length	7-bit(Fixed)	8-bit(Fixed)
Data type	ASCII	Binary
Error detecting	LRC (Longitudinal Redundancy Check)	CRC-16 (Cyclic Redundancy Check)
Data time interval	Under 1sec.	Under 24-bit time

▣ The Frame Structure of MODBUS protocol

▶ Modbus ASCII

Protocol Header	Address	Function Code	Data	LRC Check	Protocol Tail
1 character	2 character	2 character	N character	2 character	2 character (CR+LF)

▶ Modbus RTU

Protocol Header	Address	Function Code	Data	LRC Check	Protocol Tail
N/A	8-Bit	8-Bit	N * 8-Bit	16-Bit	N/A

- N : Number of Hexadecimal data

6.2 Function Code

TEMP2500 MODBUS protocol provides two function code subsets for READ/WRITE of D-Register and Loop-Back detecting test.

Function Code	Description
03	Read data in consecutive D-Register in sequence
06	Write data to arbitrary single D-Register
08	Diagnostics(Loop-Back Test)
16	Write data to consecutive D-Register in sequence



When using MODBUS, D-Register has to be subtracted '1' from the D-Register table we offer this manual, because it starts '0' D-Register address on MODBUS protocol.

6.3 Function code – 03

Function code-03 is used to read the data of consecutive D-Register block in sequence up to 64 registers.

Request Message Frame

Factor	ASCII	RTU
Protocol Header	:(Colon)	-
Slave Address	2 characters	8-Bit
Function code-03	2 characters	8-Bit
D-Register Hi	2 characters	8-Bit
D-Register Lo	2 characters	8-Bit
Address Count Hi	2 characters	8-Bit
Address Count Lo	2 characters	8-Bit
Error detecting	2 characters	16-Bit
Protocol Tail	2 characters (CR+LF)	-

Exmample

Request message to read the D-Register **FROM** D0001 (NPV) **TO** D0003 (NSP) should be

- MODBUS ASCII :010300000003F9[cr][lf]
- MODBUS RTU 01030000000305CB

☞ D-Register has to be subtracted '1' from the designated address number on D-Register table in this manual.

Response Message Frame

Factor	ASCII	RTU
Protocol Header	:(Colon)	-
Slave Address	2 characters	8-Bit
Function code-03	2 characters	8-Bit
Data byte count	2 characters	8-Bit
Data - 1 Hi	2 characters	8-Bit
Data - 1 Lo	2 characters	8-Bit
...
Data - n Hi	2 characters	8-Bit
Data - n Lo	2 characters	8-Bit
Error detecting	2 characters	16-Bit
Protocol Tail	2 characters (CR+LF)	-

Exmample

Response data will be same as below, when 49.3 of D0001 (NPV) and 10.8 of D0003 (NSP)

- MODBUS ASCII :01030601ED0000006C9C[cr][lf]
- MODBUS RTU 01030601ED0000006C8C9E

6.4 Function code – 06

Function code-06 is used to write data in arbitrary single D-Register.

Request Message Frame

Factor	ASCII	RTU
Protocol Header	:(Colon)	-
Slave Address	2 characters	8-Bit
Function code-06	2 characters	8-Bit
D-Register Hi	2 characters	8-Bit
D-Register Lo	2 characters	8-Bit
Write Data Hi	2 characters	8-Bit
Write Data Lo	2 characters	8-Bit
Error detecting	2 characters	16-Bit
Protocol Tail	2 characters (CR+LF)	-

◆ Exmample

Request message to write '2' to D0100 (pattern number) should be

- MODBUS ASCII :01060063000294[cr][lf]
- MODBUS RTU 010600630002F815

☞ D-Register has to be subtracted '1' from the designated address number on D-Register table in this manual.

Response Message Frame

Factor	ASCII	RTU
Protocol Header	:(Colon)	-
Slave Address	2 characters	8-Bit
Function code-06	2 characters	8-Bit
D-Register Hi	2 characters	8-Bit
D-Register Lo	2 characters	8-Bit
Write Data Hi	2 characters	8-Bit
Write Data Lo	2 characters	8-Bit
Error detecting	2 characters	16-Bit
Protocol Tail	2 characters (CR+LF)	-

◆ Exmample

Without any trouble, response message will be.

- MODBUS ASCII :01060063000294[cr][lf]
- MODBUS RTU 010600630002F815

6.5 Function code – 08

Function code-08 is used to test loopback for self-diagnosis.

Request Message Frame

Factor	ASCII	RTU
Protocol Header	:(Colon)	-
Slave Address	2 characters	8-Bit
Function code-08	2 characters	8-Bit
Diagnosis code Hi	2 characters	8-Bit
Diagnosis code Lo	2 characters	8-Bit
Data Hi	2 characters	8-Bit
Data Lo	2 characters	8-Bit
Error detecting	2 characters	16-Bit
Protocol Tail	2 characters (CR+LF)	-

◆ Example

Request message to test loopback for self-diagnosis should be

- MODBUS ASCII :010800000002F5[cr][lf]
- MODBUS RTU 01080000000261CA

Response Message Frame

Factor	ASCII	RTU
Protocol Header	:(Colon)	-
Slave Address	2 characters	8-Bit
Function code-08	2 characters	8-Bit
Diagnosis code Hi	2 characters	8-Bit
Diagnosis code Lo	2 characters	8-Bit
Data Hi	2 characters	8-Bit
Data Lo	2 characters	8-Bit
Error detecting	2 characters	16-Bit
Protocol Tail	2 characters (CR+LF)	-

◆ Example

Without any trouble, response message will be.

- MODBUS ASCII :010800000002F5[cr][lf]
- MODBUS RTU 01080000000261CA

6.6 Function code – 16

Function code-16 is used to write the data into consecutive D-Register block in sequence up to 64 registers.

Request Message Frame

Factor	ASCII	RTU
Protocol Header	:(Colon)	-
Slave address	2 characters	8-Bit
Function code-16	2 characters	8-Bit
D-Register Hi	2 characters	8-Bit
D-Register Lo	2 characters	8-Bit
Address Count Hi	2 characters	8-Bit
Address Count Lo	2 characters	8-Bit
Data byte Count	2 characters	8-Bit
Data – 1 Hi	2 characters	8-Bit
Data – 1 Lo	2 characters	8-Bit
...
Data – n Hi	2 characters	8-Bit
Data – n Lo	2 characters	8-Bit
Error detecting	2 characters	-
Protocol Tail	2 characters (CR+LF)	16-Bit

Example

Request message to write '99' to the D0115(TEMI.OP_H) and '50' to the D0116(TEMI.OP_M) on FIX mode operation should be

- MODBUS ASCII :0110007200020400630032E2[cr][lf]
- MODBUS RTU 01100072000204006300320499

Response Message Frame

Factor	ASCII	RTU
Protocol Header	:(Colon)	-
Slave address	2 characters	8-Bit
Function code-16	2 characters	8-Bit
D-Register Hi	2 characters	8-Bit
D-Register Lo	2 characters	8-Bit
Address Count Hi	2 characters	8-Bit
Address Count Lo	2 characters	8-Bit
Error detecting	2 characters	16-Bit
Protocol Tail	2 characters (CR+LF)	-

Example

Without any trouble, response message will be.

- MODBUS ASCII :0110007200027B[cr][lf]
- MODBUS RTU 011000720002E1D3

7. D-REGISTER Description

D-Register is group of communication data to monitor and control all status of TEMI2500.

D-Register is grouped by consecutive 100 addresses based on its concerned function as shown below.

D-Register address	Group Name	Description	Read	Write
D0001~D0099	PROCESS	General operation process information	○	◆
D0100~D0199	FUNCTION	Operating Function setting	○	○
D0200~D0299	RESERVATION	Time & Reserve operation setting	○	△
D0300~D0399	ON/OFF SIGNAL	ON/OFF signal setting	○	○
D0400~D0499	INNER SIGNAL	INNER signal setting	○	○
D0500~D0599	ALARM SIGNAL	ALARM signal setting	○	○
D0600~D0699	SEG ALARM SIGNAL	SEGMENT ALARM signal setting	○	○
D0700~D0799	TIME SIGNAL	TIME signal setting	○	○
D0800~D0899	COMMUNICATION	Communication concerned information	○	△
D0900~D0999	PICTURE	USER SCREEN setting	○	○
D1000~D1099	PID1	P.I.D setting-1	○	○
D1100~D1199	PID2	P.I.D setting-2	○	○
D1200~D1299	INPUT	Sensor Input setting	○	○
D1300~D1399	OUTPUT	Control&retransmission Output setting	○	○
D1400~D1499	D0 CONFIG1	D0(Digital Output) Relay setting-1	○	○
D1500~D1599	D0 CONFIG2	D0(Digital Output) Relay setting-2	○	○
D1600~D1699	DI CONFIG1	DI(Digital Input) setting	○	○
D1700~D1799	DI CONFIG2	DI NAME input-1	○	○
D1800~D1899	DI CONFIG3	DI NAME input-2	○	○
D1900~D1999	INITIAL1	Initial system setting-1	○	○
D2000~D2099	INITIAL2	Initial system setting-2	○	◆
D2100~D2199	PROGRAM	Program pattern profile setting	○	○
D2200~D2299	PATTERN INFO	Pattern profile information	○	◆
D2300~D3999	FILE1 ~ FILE17	Recorded Trend file information	○	◆

☞ D-Register is composed of hexadecimal 4 digit (2-Byte).

- ○ : Available to read / write over all designated address range.
- △ : Available to read / write in part of designated address range.
- ◆ : Not available to read / write over all designated address range.

7.1 PROCESS

PROCESS group consists of fundamental parameter information concerned with operation process and status. Below table describes the detail Bit Map information of some parameter that indicates its status by Bit.

■ Bit Map information of TEMP2500

BIT	NOW.STS	IS.STS	TS.STS	ALM.STS	SEGALM.STS	ONOFF.STS	ADERR.STS
	(D0010)	(D0012)	(D0014)	(D0016)	(D0018)	(D0020)	(D0022)
0	RESET	IS1	TS1	ALM1	SEGALM1	T1	+OVER
1	FIX	IS2	TS2	ALM2	SEGALM2	T2	-OVER
2	PROG	IS3	TS3	ALM3	SEGALM3	T3	S.OPN
3	HOLD	IS4	TS4	ALM4	SEGALM4	T4	
4	WAIT	IS5	TS5			T5	
5	AT	IS6	TS6			T6	
6		IS7	TS7			T7	
7		IS8	TS8				
8							
9							
10							
11							
12							
13							
14							
15							

BIT	DOCTR.STS	CTR.STS	D0.STS1	D0.STS2	DI.DATA	SYS.STS	
	(D0024)	(D0026)	(D0028)	(D0029)	(D0030)	(D0031)	
0	RUN	RUN	D01	D017	D11	DISP.COMERR	
1	WAIT	WAIT	D02	D018	D12	IO.COMERR	
2	UP	UP	D03	D019	D13	SD.INSERT	
3	DOWN	DOWN	D04	D020	D14		
4	SOAK	SOAK	D05	D021	D15		
5	FEND	FEND	D06	D022	D16		
6	PTEND	PTEND	D07	D023	D17		
7	1REF	1REF	D08	D024	D18		
8	2REF	2REF	D09	D025	D19		
9			D010	D026	D110		
10			D011	D027	D111		
11			D012	D028	D112		
12			D013	D029	D113		
13			D014	D030	D114		
14			D015	D031	D115		
15			D016	D032	D116		

■ Bit Map status information D-Register

D-Reg.	Symbol	Descriptions
D0010	NOW.STS	Current operation status information.
D0012	IS.STS	INNER signal generating status information.
D0014	TS.STS	TIME signal generating status information.
D0016	ALM.STS	ALARM signal generating status information.
D0018	SEGALM.STS	SEGMENT ALARM signal generating status information.
D0020	ONOFF.STS	ON/OFF signal generating status information.
D0022	ADERR.STS	Error status out of control range.
D0024	DOCTR.STS	Other D0 signal generating status information.
D0026	CTR.STS	Displayed D0 signal status information on 2 nd Oper screen
D0028	D0.STS1	Actual generating Do signal status through I/O board
D0029	D0.STS2	
D0030	DI.DATA	DI Error outbreak status information.
D0031	SYS.STS	The main control and display or the main control and I / O relay board Communication error occurs and the SD card used in the information indicates.

■ Common process information D-Register for both PROG / FIX

D-Reg.	Symbol	Descriptions
D0001	NPV	Current PV
D0003	NSP	Current SP
D0005	MVOUT	Current control output
D0007	CPIDNO	Currently running PID number
D0034	RUN.TIME_H	Process time (Hour)
D0035	RUN.TIME_M	Process time (Minute)
D0036	RUN.TIME_S	Process time (Second)
D0071	HMVOUT	[HEAT]Current control output
D0073	CMVOUT	[COOL]Current control output

■ PROGRAM operation process information D-Register

D-Reg.	Symbol	Descriptions
D0040	RUN.PTNO	Currently running program pattern number
D0041	RUN.SEGNO	Currently running program segment number
D0044	NOW.PT.RPT	Count of current Repeat operation at running pattern
D0045	TOTAL.PT.RPT	Total Programmed Count of Repeat op. at running pattern
D0048	NOW.SEG.RPT	Count of current Repeat operation at running segment
D0049	TOTAL.SEG.RPT	Total Programmed Count of Repeat op. at running segment
D0052	NOW.SEGTM_H	Process time(High) of currently running segment
D0053	NOW.SEGTM_L	Process time(Low) of currently running segment
D0054	TOTAL.SEGTM_H	Programmed total time(High) of currently running segment
D0055	TOTAL.SEGTM_L	Programmed total time(Low) of currently running segment
D0060	PREV.TSP	Target Set Point of the preceding segment
D0061	NOW.TSP	Target Set Point of the current segment
D0065	USED PATTERN	Total number of programmed pattern
D0066	USED SEGMENT	Total number of programmed segment

7.2 FUNCTION Group

FUNCTION group consists of setting parameter D-register related with operational function and process.

■ Common Operational Function setting D-Register for both PROG / FIX

D-Reg.	Symbol	Descriptions
D0112	FUZZY	FUZZY Function (0:OFF, 1:ON)
D0121	KEYLOCK	KEYLOCK Function (0:OFF, 1:ON)
D0126	DRAW.CYCLE	Sampling time for recording on internal memory
D0127	PV.GRP_RECORD	Activating to record on internal memory (0:OFF, 1:ON)
D0130	REC.OP	Activating to record on SD memory card (0:OFF, 1:ON)
D0131	REC.CYCLE	Sampling time for recording on SD memory card
D0132	BACK.ITEM	BACKUP ITEM setting(0:PTN, 1:PARA, 2:ALL)
D0133	BACK.DIR	BACKUP DIRECTION setting
D0136	AT	Carrying out Auto-Tuning (0:OFF, 1:ON)
D0150	PV.FONT	PV FONT select (0:HEAD, 1:NORM, 2:ART)
D0151	BUZ.ONOFF	Buzzer sound (0: UNUSE, 1: USE)
D0152	LIGHT.OFFTM	Backlight ON time
D0160	UTAG_USING	Tags enable (0:OFF, 1:ON)
D0161 ~ D0163	UTAG.NAME1~ UTAG.NAME3	Tag name is set up to 6 digits.

■ PROGRAM Operation & Function setting D-Register

D-Reg.	Symbol	Descriptions
D0100	SET.PTNO	Pattern Number to run program operation
D0140	WAIT.USE	WAIT Function (0:UNUSE, 1:USE)
D0142	WAIT_ZONE	WAIT ZONE setting
D0144	WAIT_TIME	WAIT TIME setting
D0146	WAIT.METHOD	Target of WAIT function (0:ALL, 1:SEG)

■ FIX Operation & Function setting D-Register

D-Reg.	Symbol	Descriptions
D0104	FIX.TSP	Set Point on FIX operation
D0110	SLOPE	UP/DOWN Setting the slope
D0114	TIME.OP	TIME OPERATION (0:UNUSE, 1:USE)
D0115	TIME.OP_H	HOUR setting for TIME OPERATION
D0116	TIME.OP_M	MINUTE & SEC setting for TIME OPERATION

■ OPERATION mode & performance setting D-Register

D-Reg.	Symbol	Process method	Setting	Description
D0102	COM.OPMODE	RUN	1	Start running PROG/FIX Oper.
		HOLD	2	HOLD ON/OFF
		STEP	3	Segment STEP
		STOP	4	Stop PROG/FIX Operation
D0106	OP.MODE	PROG	0	Set PROG Operation MODE
		FIX	1	Set FIX Operation MODE
D0108	PWR.MODE	STOP	0	Not using Power-Mode
		COLD	1	COLD MODE
		HOT	2	HOT MODE

☞ To activate PROG operation RUN or FIX operation RUN, TEMP2500 should be in individual corresponding STOP(PROG STOP/FIX STOP) state. For example, to activate PROG operation RUN from currently operating FIX RUN state, convert the operation state to PROG STOP (D0106 = 0000, D0102 = 0004) first, then you can activate PROG operation RUN.

7.3 RESERVATION Group

RESERVATION TEMP2500 hours of group identification, and book set, PROGRAM driver's start time and end time of operation consists of related D-Register.

■ TIME setting and information D-Register

D-Reg.	Symbol	Description	Read	Write
D0202	NOW.YEAR	Current YEAR installed in TEMP2500	○	×
D0203	NOW.MONTH	Current MONTH installed in TEMP2500	○	×
D0204	NOW.DAY	Current DAY installed in TEMP2500	○	×
D0205	NOW.AMPM	Current TIME-AM/PM installed in TEMP2500	○	×
D0206	NOW.HOUR	Current HOUR installed in TEMP2500	○	×
D0207	NOW.MIN	Current MN. installed in TEMP2500	○	×
D0208	C.YEAR	Current YEAR setting in TEMP2500	×	○
D0209	C.MONTH	Current MONTH setting in TEMP2500	×	○
D0210	C.DAY	Current DAY setting in TEMP2500	×	○
D0211	C.AMPM	Current TIME-AM/PM setting in TEMP2500	×	○
D0212	C.HOUR	Current HOUR setting in TEMP2500	×	○
D0213	C.MIN	Current MN. setting in TEMP2500	×	○
D0214	R.YEAR	YEAR setting for RESERVE Operation	○	○
D0215	R.MONTH	MONTH setting for RESERVE Operation	○	○
D0216	R.DAY	DAY setting for RESERVE Operation	○	○
D0217	R.AMPM	TIME-AM/PM setting for RESERVE Operation	○	○
D0218	R.HOUR	HOUR setting for RESERVE Operation	○	○
D0219	R.MIN	MIN. setting for RESERVE Operation	○	○

■ RESERVE Operation

D-Reg.	Symbol	Operation	Setting	Description
D0200	RESERVE	OFF	0	Release RESERVE Oper.
		ON	1	Set RESERVE Oper.

■ PROGRAM Start time and end time running

D-Reg.	Symbol	Description
D0260	CH1_TIME_VALID	Show start time and end time (0: Normal, 1:---.-)
D0261	CH1_START_YEAR	Setting start time (Year)
D0262	CH1_START_MON	Setting start time (Month)
D0263	CH1_START_DAY	Setting start time (Day)
D0264	CH1_START_HOUR	Setting start time (Hour)
D0265	CH1_START_MIN	Setting start time (Min)
D0266	CH1_END_YEAR	Setting end time (Year)
D0267	CH1_END_MON	Setting end time (Month)
D0268	CH1_END_DAY	Setting end time (Day)
D0269	CH1_END_HOUR	Setting end time (Hour)
D0270	CH1_END_MIN	Setting end time (Min)

7.4 ON/OFF SIGNAL Group

This setting parameter D-register group is used to establish 6 ON/OFF SIGNALs.

■ ON/OFF SIGNAL setting D-Register

D-Reg.	Symbol	Description
D0301	T1.LSP	Low SP for ON/OFF SIGNAL T1
D0302	T1.MSP	Middle SP for ON/OFF SIGNAL T1
D0303	T1.HSP	High SP for ON/OFF SIGNAL T1
D0304	T1.HDV	High zone Deviation for operating Point at High Zone T1
D0305	T1.LDV	Low zone Deviation for operating Point at Low Zone T1
.	.	.
.	.	.
.	.	.
D0336	T6.LSP	Low SP for ON/OFF SIGNAL T6
D0337	T6.MSP	Middle SP for ON/OFF SIGNAL T6
D0338	T6.HSP	High SP for ON/OFF SIGNAL T6
D0339	T6.HDV	High zone Deviation for operating Point at High Zone T6
D0340	T6.LDV	Low zone Deviation for operating Point at Low Zone T6

7.5 INNER SIGNAL Group

This setting parameter D-register group is used to establish 8 INNER SIGNALs.

■ INNER SIGNAL setting D-Register

D-Reg.	Symbol	Descriptions
D0401	IS1.TYPE	Object Type of Target of INNER SIGNAL1 (0:SP, 1:PV, 2:MV)
D0402	IS1.BAND	Direction Band of INNER SIGNAL1 (0:IN-B, 1:OUT-B)
D0403	IS1.RH	Range High of INNER SIGNAL1
D0404	IS1.RL	Range Low of INNER SIGNAL1
D0405	IS1.DYT	DELAY TIME of INNER SIGNAL1
.	.	.
.	.	.
.	.	.
D0443	IS8.TYPE	Object Type of Target of INNER SIGNAL8 (SP/PV/MV)
D0444	IS8.BAND	Direction Band of INNER SIGNAL8 (IN-B/OUT-B)
D0445	IS8.RH	Range High of INNER SIGNAL8
D0446	IS8.RL	Range Low of INNER SIGNAL8
D0447	IS8.DYT	DELAY TIME of INNER SIGNAL8

7.6 ALARM SIGNAL Group

This setting parameter D-register group is used to establish 4 ALARM signals.

■ ALARM signal setting D-Register

D-Reg.	Symbol	Descriptions
D0501	ALM.OP	Condition of ALARM Operation (0:RUN, 1:ALWAYS)
D0505	ALM1.TYPE	Type of ALARM signal 1
D0506	ALM1.POINT	Target Point of ALARM signal 1
D0507	ALM1.H_POINT	Limit High point of ALARM signal 1
D0508	ALM1.L_POINT	Limit Low point of ALARM signal 1
D0509	ALM1.HYS	Hysteresis of ALARM signal 1
D0510	ALM1.DYT	DELAY TIME of ALARM signal 1
.	.	.
.	.	.
.	.	.
D0526	ALM4.TYPE	Type of ALARM signal 4
D0527	ALM4.POINT	Target Point of ALARM signal 4
D0528	ALM4.H_POINT	Limit High point of ALARM signal 4
D0529	ALM4.L_POINT	Limit Low point of ALARM signal 4
D0530	ALM4.HYS	Hysteresis of ALARM signal 4
D0531	ALM4.DYT	DELAY TIME of ALARM signal 4

7.7 SEGMENT ALARM SIGNAL Group

This setting parameter D-register group is used to establish 8 SEGMENT ALARM signals.

■ SEGMENT ALARM signal setting D-Register

D-Reg.	Symbol	Descriptions
D0601	SA1.TYPE	Type of SEGMENT ALARM signal 1
D0602	SA1.POINT	Target Point of SEGMENT ALARM signal 1
D0603	SA1.H_POINT	Limit High point of SEGMENT ALARM signal 1
D0604	SA1.L_POINT	Limit Low point of SEGMENT ALARM signal 1
D0605	SA1.HYS	Hysteresis of SEGMENT ALARM signal 1
D0606	SA1.DYT	DELAY TIME of SEGMENT ALARM signal 1
.	.	.
.	.	.
.	.	.
D0643	SA8.TYPE	Type of SEGMENT ALARM signal 8
D0644	SA8.POINT	Target Point of SEGMENT ALARM signal 8
D0645	SA8.H_POINT	Limit High point of SEGMENT ALARM signal 8
D0646	SA8.L_POINT	Limit Low point of SEGMENT ALARM signal 8
D0647	SA8.HYS	Hysteresis of SEGMENT ALARM signal 8
D0648	SA8.DYT	DELAY TIME of SEGMENT ALARM signal 8

7.8 TIME SIGNAL Group

This setting parameter D-register group is used to establish 19 TIME SIGNALs.

■ TIME SIGNAL setting D-Register

D-Reg.	Symbol	Descriptions
D0701	TS2DYTM_H	DELAY TIME (HOUR) of generating TIME SIGNAL 2.
D0702	TS2DYTM_L	DELAY TIME (MIN. & SEC.) of generating TIME SIGNAL 2.
D0703	TS2KPTM_H	OPER.TIME (HOUR) to keep generating TIME SIGNAL 2.
D0704	TS2KPTM_L	OPER.TIME (MIN. & SEC.) to keep generating TIME SIGNAL 2.
.	.	.
.	.	.
.	.	.
D0773	TS20DYTM_H	DELAY TIME (HOUR) of generating TIME SIGNAL 20.
D0774	TS20DYTM_L	DELAY TIME (MIN. & SEC.) of generating TIME SIGNAL 20.
D0775	TS20KPTM_H	OPER.TIME (HOUR) to keep generating TIME SIGNAL 20.
D0776	TS20KPTM_L	OPER.TIME (MIN. & SEC.) to keep generating TIME SIGNAL 20.

7.9 COMMUNICATION Group

This group is consists of information parameter D-Register concerned communication.

■ COMMUNICATION concerned information D-Register

D-Reg.	Symbol	Descriptions
D0801	COM2.PROTOCOL	[COM2] Communication Protocol information
D0802	COM2.BPS	[COM2] Communication speed (Baud Rate) information.
D0803	COM2.PARITY	[COM2] Parity information.
D0804	COM2.STOP.BIT	[COM2] Stop Bit information.
D0805	COM2.DATA.LENGTH	[COM2] Data Length information.
D0806	COM2.ADDRESS	[COM2] Slave Address information.
D0807	COM2.RESPONSE	[COM2] Response Time information.
D0808	COM4.BPS	[COM4] Communication speed (Baud Rate) information.
D0809	SYNC.MST	SYNC Master (0:OFF, 1:ON)

7.10 PICTURE Group

PICTURE group consists of setting parameter D-Register for User Screen viewer.

■ PICTURE setting D-Register

D-Reg.	Symbol	Descriptions
D0901	VIEW.ROTATE	Setting for using User Screen viewer.
D0902	R.ST_TIME	START TIME by no key input to activate User Screen Viewer
D0903	R.INT_TIME	INTERVAL TIME to display next image.

7.11 PID Group

This setting parameter D-register group is used to establish 6 PID GROUP

■ PID setting D-Register

D-Reg.	Symbol	Descriptions
D1001	RP1	Reference Point 1 (T1) to define PID ZONE.
D1002	RP2	
D1003	RP3	
D1004	RP4	
D1009	RHYS	Selects hysteresis when ZONE PID.
D1010	RDEV	Sets deviation for selecting deviation PID.
D1013	CMOD	Select the control method. (0:D.PV, 1:D.DV)
D1015	AT.POINT	Auto-tuning sets the reference value.
D1017	AT.DISPLAY	Setting to display or hide AT KEY. (0:HIDE, 1:DISPLAY)
D1019	PID.OPMODE	Select sets of PID. (0:SEG, 1:ZONE)
D1021	PID.APP	ZONE PID sets of selection criteria. (0:PV, 1:SP)
D1065	1.DB	Setting of the DEAD BAND for PID 1 in H/C TYPE
.	.	.
.	.	.
.	.	.
D1070	6.DB	Setting of the DEAD BAND for PID 6 in H/C TYPE
D1079	HCHYS	Setting the hysteresis value to be applied to internal control output value in Heating,Cooling, ON/OFF control

■ General(Heating) PID setting D-Register

D-Reg.	Symbol	Descriptions
D1101	1_HP	Proportional band of PID1
D1102	1_HI	Integral time of PID1
D1103	1_HD	Differential time of PID1
D1104	1_HOH	Control Output High limit of PID1
D1105	1_OL	Control Output Low limit of PID1
D1106	1_MR	Integral time of PID1 is set manually.
D1107	1_HHYS	PID1 the ON / OFF control hysteresis High limit is set at.
D1108	1_LHYS	PID1 the ON / OFF control hysteresis at the Low setting.
.	.	.
.	.	.
.	.	.
D1141	6_HP	Proportional band of PID1
D1142	6_HI	Integral time of PID1
D1143	6_HD	Differential time of PID1
D1144	6_HOH	Control Output High limit of PID1
D1145	6_HOL	Control Output Low limit of PID1
D1146	6_MR	Integral time of PID1 is set manually.
D1147	6_HHYS	PID1 the ON / OFF control hysteresis High limit is set at.
D1148	6_LHYS	PID1 the ON / OFF control hysteresis at the Low setting.
D1082	1.HOH	Set the upper limit of the output PID1.
.	.	.
.	.	.
.	.	.
D1087	6.HOH	Set the upper limit of the output PID6.

■ Cooling PID setting D-Register

D-Reg.	Symbol	Descriptions
D1025	1._CP	Proportional band of PID1
D1026	1._CI	Integral time of PID1
D1027	1._CD	Differential time of PID1
	.	.
	.	.
	.	.
D1040	6._CP	Proportional band of PID1
D1041	6._CI	Integral time of PID1
D1042	6._CD	Differential time of PID1
D1088	1.CO1	Set the upper limit of the output PID1.
.	.	.
.	.	.
.	.	.
D1093	6.CO1	Set the upper limit of the output PID6.

7.12 INPUT Group

This INPUT group is used for setting parameter D-Register for sensor and its bias.

■ INPUT setting D-Register

D-Reg.	Symbol	Descriptions
D1201	SENGP	Select the sensor group. (0:T/C, 1:RTD, 2:DCV)
D1202	SENTP	Sets the type of sensor.
D1203	UNIT	Sets the sensor unit.
D1204	DP	Set-point position.
D1205	TCSL	T/C select show (0:T/C, 1:T/C+RJC, 2:RJC)
D1206	SOPN.SEL	Sensors-open, pv select the direction. (0:UNSET, 1:UP, 2:DOWN)
D1207	INRH	Sets the High limit range of use.
D1208	INRL	Sets the Low limit range of use.
D1209	BIAS	Sets the previous range revision value.
D1210	INFL	Removes noise when measuring input includes noise of high frequency.
D1212	INSH	Scale sets the High limit.
D1213	INSL	Scale sets the Low limit.
D1231~D1238	BP1.DDV~BP8.DDV	Sets revision temperature at each standard temperature.
D1239~D1246	BP1.DPV~BP8.DPV	Sets each standard temperature.
D1270, D2071	UNITNAME1, UNITNAME2	Setting the DCV sensor display unit name.

7.13 OUTPUT Group

This INPUT group is used for setting parameter D-Register for control output and retransmission.

■ Control output and retransmission setting D-Register

D-Reg.	Symbol	Descriptions
D1301~ D1304	OUT1.TYPE~ OUT4.TYPE	Setting the output terminal of OUT1~OUT4.
D1309	DIR	Select the direction of behavior.(0:REV, 1:FWD)
D1311	ARW	ARW(Anti Reset Wind-up) sets the value of prevention
D1313	UPOPR	Change the setting up of the control output.
D1314	DNOPR	Change the setting of control output is falling.
D1317	HCT	[HEAT] Sets the output cycle.
D1319	HPO	[HEAT] Output is in an emergency setting.
D1321	HATG	[HEAT] Auto-Tuning GAIN value for Manual PID.
D1325	RETT	Target object of transmission (0:PV, 1:SP, 2:MV)
D1327	RETH	Range High of transmission
D1328	RETL	Range Low of transmission
D1333	CCT	[COOL] Sets the output cycle.
D1335	CPO	[COOL] Output is in an emergency setting.
D1337	CAGT	[COOL] Auto-Tuning GAIN value for Manual PID.
D1341~D1344	OUT1.MODE~OUT4.MODE	Setting the output type of OUT1~OUT4. (0:SSR, 1:SCR)

7.14 DO CONFIG Group

DO CONFIG group consists of setting and information parameter D-Register related to establish RELAY number on I/O board to generate signal and its sub setting for auxiliary Digital Output.

■ DO CONFIG setting and information D-Register

D-Reg.	Symbol	Descriptions
D1401~D1408	IS1.RLY~IS8.RLY	RELAY No.on I/O for INNER SIGNAL.
D1417~D1424	TS1.RLY~TS8.RLY	RELAY No.on I/O for TIME SIGNAL.
D1433~D1436	ALM1.RLY~ALM4.RLY	RELAY No.on I/O ALARM SIGNAL.
D1441~D1444	SA1.RLY~SA4.RLY	RELAY No.on I/O SEGMENT ALARM SIGNAL.
D1449~D1462	T1.RLY~T7.DYT	RELAY No.on I/O and DELAY TIME for ON/OFF SIGNAL.
D1501,D1502	RUN.RLY,RUN.DYT	RELAY No.on I/O and DELAY TIME for RUN SIGNAL.
D1505,D1506	SOPN.RLY,SOPN.KPT	RLY No.on I/O and KEEP TIME for SENSOR-OPEN SIGNAL.
D1509,D1510	WAIT.RLY,WAIT.KPT	REALY No.on I/O and KEEP TIME for WAIT SIGNAL.
D1513,D1514	UP.RLY,UP.DEV	RELAY No.on I/O and DEVIATION for UP SIGNAL.
D1517,D1518	SOAK.RLY,SOAK.KPT	REALY No.on I/O and KEEP TIME for SOAK SIGNAL.
D1521,D1522	DOWN.RLY,DOWN.DEV	RELAY No.on I/O and DEVIATION for DOWN SIGNAL
D1525,D1526	FEND.RLY,FEND.KPT	RLY No.on I/O and KEEP TIME for FIX-END SIGNAL.
D1529,D1530	PTEND.RLY,PTEND.KPT	RLY No.on I/O and KEEP TIME for PROGRAM PTN-END SIGNAL.
D1533,D1534	1REF.RLY,1REF.DYT	RELAY No.on I/O and DELAY TIME for 1 st Refrigerator oper.
D1535,D1536	2REF.RLY,2REF.DYT	RELAY No.on I/O and DELAY TIME for 2 nd Refrigerator oper.
D1541,D1542	ERROR.RLY,ERROR.KPT	REALY No.on I/O and KEEP TIME for ERROR SIGNAL.
D1545	UKEY.RLY	RELAY No.on I/O for USER KEY SIGNAL.
D1546~D1561	D11.RLY~D116RLY	RELAY No.on I/O for DI SIGNAL.
D1562~D1573	USER.RLY1~USER.RLY12	RELAY No.on I/O for MANUAL SIGNAL.
D1574	USER.RLY_ON/OFF	Switch "ON" the relay for the corresponding number manually.
D1575,D1576	FEND.DLT,PTEND.DLT	DELAY TIME for FIX-END and PATTERN-END SIGNAL.
D1581,D1582	FIXTIMER.RLY,FIXTIMER.DEV	RELAY No.on I/O and DEVIATION for FIXTIMER SIGNAL
D1583,D1584	FIXTIMER.DLY,FIXTIMER.OPT	DELAY TIME and OPERATION TIME for FIXTIMER SIGNAL
D1591,D1592	UP.DEVSEL, DN.DEVSEL	Operating conditions for UP and DOWN SIGNAL. (Operating conditions 0:[TSP-NSP] ,1:[TSP-NPV])
D1670	LOG.OUTRLY1	REALY No.on I/O for LOGICAL SIGNAL1.
D1671	LOG.SRCLRYa1	Operand relay-a for LOGICAL SIGNAL1.
D1672	LOG.SRCLRYb1	Operand relay-b for LOGICAL SIGNAL1.
D1673	LOG.OPERAND1	Operator for LOGICAL SIGNAL1.
.	.	.
.	.	.
.	.	.
D1678	LOG.OUTRLY3	REALY No.on I/O for LOGICAL SIGNAL3.
D1679	LOG.SRCLRYa3	Operand relay-a for LOGICAL SIGNAL3.
D1680	LOG.SRCLRYb3	Operand relay-b for LOGICAL SIGNAL3.
D1681	LOG.OPERAND3	Operator for LOGICAL SIGNAL3.

7.15 DI CONFIG Group

DI CONFIG group consists of setting parameter D-Register for DI ERROR and its name.

■ DI CONFIG setting D-Register

D-Reg.	Symbol	Descriptions
D1601	DISP.METHOD	DISPLAY METHOD for DI ERROR. (0:TEXT, 1:PICTURE)
D1602	BUZ.TIME	Sets time for DI Error buzzer.
D1603	DIDEC.TIME	DETECT TIME to recognize DI ERROR from actual occurrence
D1606	DI1.OP_MODE	OPERATION MODE when DI 1 ON. (0:ERROR, 1:RUN/STOP)
D1607	DI2.OP_MODE	OPERATION MODE when DI 2 ON. (0:ERROR, 1:HOLD)
D1608	DI3.OP_MODE	OPERATION MODE when DI 3 ON. (0:ERROR, 1:STEP)
D1609	DI4.OP_MODE	OPERATION MODE when DI 4 ~ 16 ON (0:ERROR, 1:PATTERN SELECTION)
D1618,D1619	DI1.OP,DI1.DYT	DI 1 OPERATION after detecting and DELAY TIME
.	.	.
.	.	.
.	.	.
D1648,D1649	DI16.OP,DI16.DYT	DI 1 OPERATION after detecting and DELAY TIME
D1652	DI1.DETECT	Setting the DI1 sensing method (0:A-TYPE, 1:B-TYPE)
.	.	.
.	.	.
.	.	.
D1667	DI16.DETECT	Setting the DI1 sensing method (0:A-TYPE, 1:B-TYPE)
D1701~D1712	DI1.NAME1~DI1.NAME12	Setting the DI1 error name.
.	.	.
.	.	.
.	.	.
D1785~D1796	DI16.NAME1~DI16.NAME12	Setting the DI16 error name

7.16 INITIAL Group

INITIAL group consists of setting parameter D-Register for system initial configuration.

■ INITIAL setting D-Register

D-Reg.	Symbol	Descriptions
D1901	LANGUAGE	Language for using TEMP2500. (0:ENG, 1:KOR, 2:CHN)
D1902	DISP.MODE	DISPLAY MODE for 'Initial Logo screen' when PWR ON. (0:TEXT, 1:PICTURE)
D1903	UKEY.USE	Setting for using USER KEY. (0:UNUSE, 1:USE)
D1906~D1918	INFORM1.NAME1 ~INFORM1.NAME13	Name of INIT INFORMATION 1 when setting 'TEXT' on DISPLAY MODE.
.	.	.
.	.	.
.	.	.
D1932~D1944	INFORM3.NAME1 ~INFORM3.NAME13	Name of INIT INFORMATION 3 when setting 'TEXT' on DISPLAY MODE.
D2001~D2051	CH1LAMP_IS1 ~CH1LAMP_DI16	STATUS DISPLAY LAM.

7.17 PROGRAM PATTERN Group and Setting

7.17.1 PROGRAM

PROGRAM group consists of parameter D-Register to arrange program PATTERN organized by each segment profile. Each segment should be established step by step.

■ Program PATTERN setting D-Register

D-Reg.	Symbol	Range	Description
D2101	COM_PTNO	1~80	Program PATTERN number to Read or Write
D2102	COM_SEGNO	0	To Read or Write in D2145~D2167
		1~99	Segment number to Read or Write
D2103	PTCOPY_START	-	First target (START) pattern number to paste
D2104	PTCOPY_END	-	Last target (END) pattern number to paste
D2105	PTDEL_START	-	First target (START) pattern number to delete
D2106	PTDEL_END	-	Last target (END) pattern number to delete
D2107	TRIGGER	1	INIT : Initialize D2101~D2108 to '0'
		2	READ : Read profiles in D2101 and D2102
		3	WRITE : Write profiles in D2101 and D2102
		4	PT COPY : Copy PTN in D2101 to PTN designated in D2103~2104
		5	PT DEL : Delete PTN designated in D2105~D2106
		6	PT NAME READ : Read PTN NAME in D2101
		7	PT NAME WRITE : Write PTN NAME in D2101
		8	ALL PT : Write pattern profile at D2101 into D2300
D2108	ANSWER	0	FULL : Excessive number of pattern or segment setting
		1	DONE : Normally accessed of D2107(TRIGGER) command
		2	PT EMPTY : No profile in designated pattern
		3	SEG EMPTY : No profile in designated segment
		4	PT RUN : Program RUN state of designated PTN
		5	PARA ERROR : Program setting Error of D2101~D2107
D2111~D2122	PATTERN_NAME1~12	-	Pattern NAME to Read or Write
D2126	TSP	-	Target Set Point(TSP) to Read or Write
D2127	SEG.TIME_H	-	Target Process time (HOUR) of segment to Read or Write
D2128	SEG.TIME_L	-	Target Process time (MIN & SEC) of segment to Read or Write
D2129	TS1	-	TS1 to Read or Write
D2130	TS2	-	TS2 to Read or Write
D2131	TS3	-	TS3 to Read or Write
D2132	TS4	-	TS4 to Read or Write
D2133	TS5	-	TS5 to Read or Write
D2134	TS6	-	TS6 to Read or Write
D2135	TS7	-	TS7 to Read or Write
D2136	TS8/AUX_OUT	-	TS8 or AUX to Read or Write
D2137	SEGAL1	-	SEGMENT ALARM1 to Read or Write
D2138	SEGAL2	-	SEGMENT ALARM2 to Read or Write
D2139	SEGAL3	-	SEGMENT ALARM3 to Read or Write
D2140	SEGAL4	-	SEGMENT ALARM4 to Read or Write
D2141	SEG_PID	-	SEGMENT PID to Read or Write

■ PROGRAM and its REPEAT operation setting D-Register

D-Reg.	Symbol	Descriptions
D2145	START.CODE	START CODE for operation (0:TPV, 1:SPV, 2:SSP)
D2146	START.SP	START SSP
D2150	PT.RPT	Count number for PATTERN REPEAT (0:Infinitely, 1 ~ 999)
D2151	PT.EMOD	PATTERN END MODE (0:RESET, 1:SEG HOLD, 2:LINK RUN)
D2152	LINK.PT	LINK PATTERN (1 ~ 80)
D2156	SEG_RPT.S1	SEGMENT REPEAT START-1
D2157	SEG_RPT.E1	SEGMENT REPEAT END-1
D2158	SEG_RPT.C1	SEGMENT REPEAT COUNT-1
D2159	SEG_RPT.S2	SEGMENT REPEAT START-2
D2160	SEG_RPT.E2	SEGMENT REPEAT END-2
D2161	SEG_RPT.C2	SEGMENT REPEAT COUNT-2
D2162	SEG_RPT.S3	SEGMENT REPEAT START-3
D2163	SEG_RPT.E3	SEGMENT REPEAT END-3
D2164	SEG_RPT.C3	SEGMENT REPEAT COUNT-3
D2165	SEG_RPT.S4	SEGMENT REPEAT START-4
D2166	SEG_RPT.E4	SEGMENT REPEAT END-4
D2167	SEG_RPT.C4	SEGMENT REPEAT COUNT-4

7.17.2 How to READ program PATTERN

▶ Below describes process step to read programmed PATTERN profile in TEMP2500.

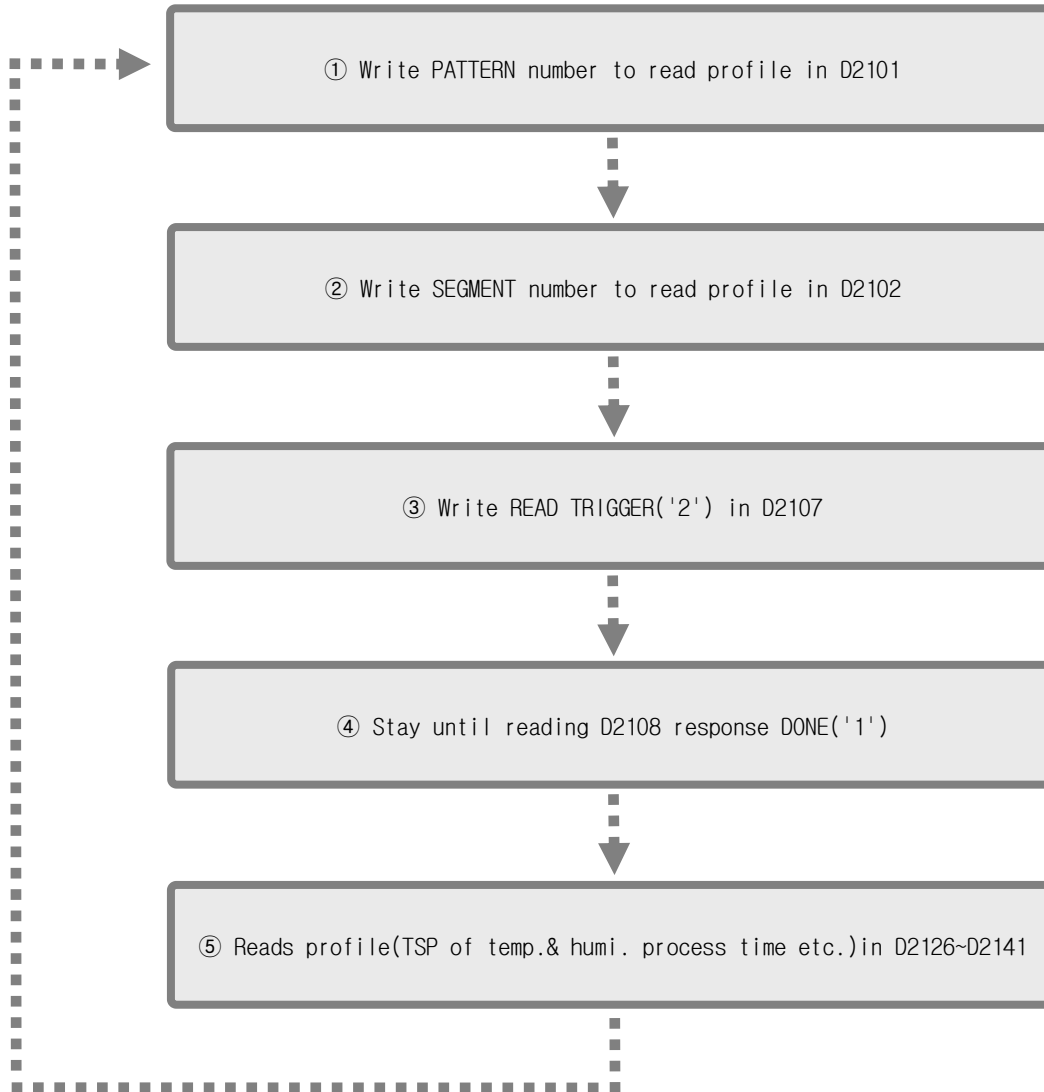

Above process step ① ~ ⑤ is used to read 'ONE SEGMENT' profile among all in programmed pattern. To read many segments, reiterate ① ~ ⑤ process step by changing segment number. Setting '0' in D2102 at process step ② will read profile in D2145~D2167.

7.17.3 How to WRITE program PATTERN

▶ Below describes process step to write programming PATTERN profile in TEMP2500.

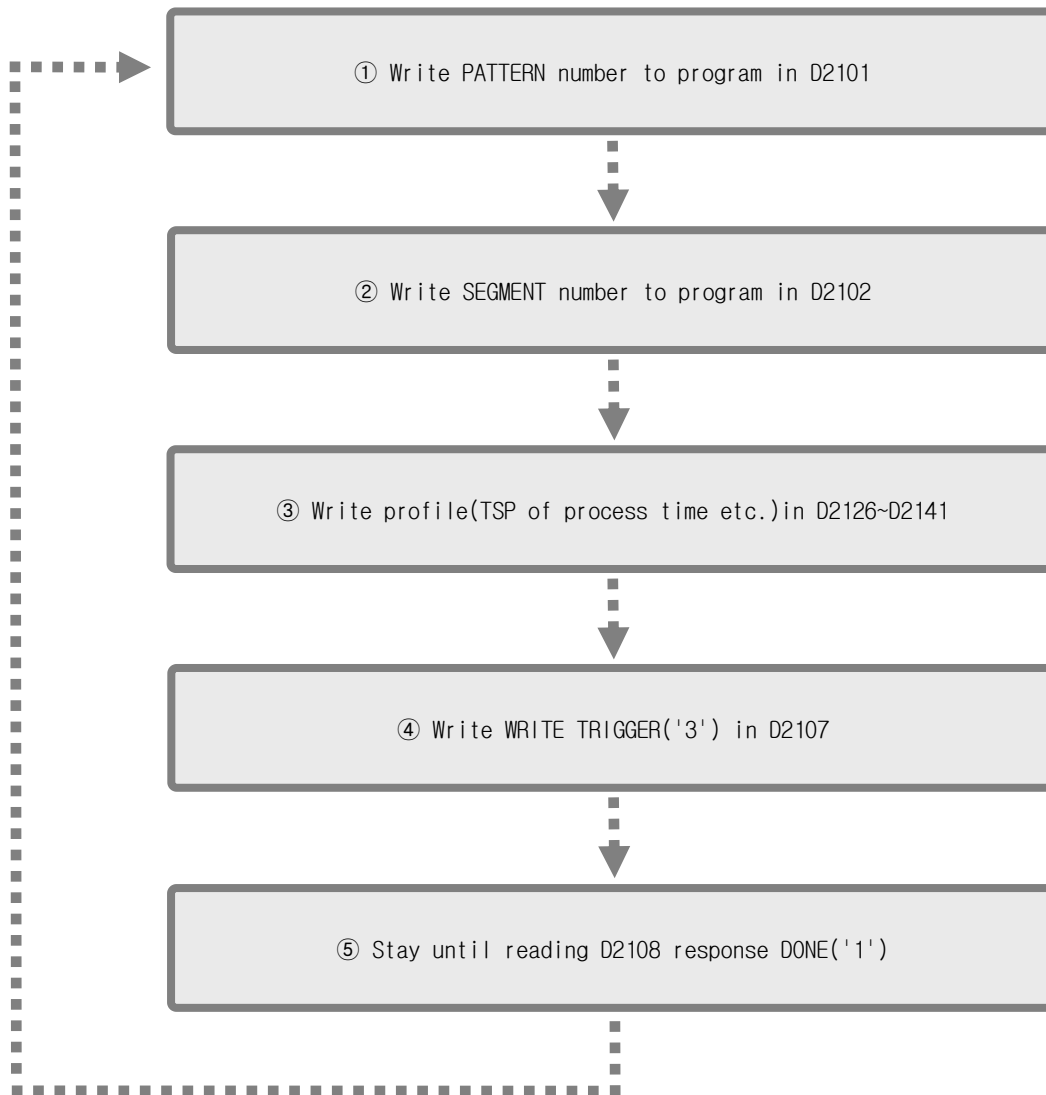

Above process step ① ~ ⑤ is used to write 'ONE SEGMENT' profile among all in programmed pattern. Reiterate ① ~ ⑤ process step by changing segment number to write many segments.

► Below describes process step to write program in D2145~D2167.

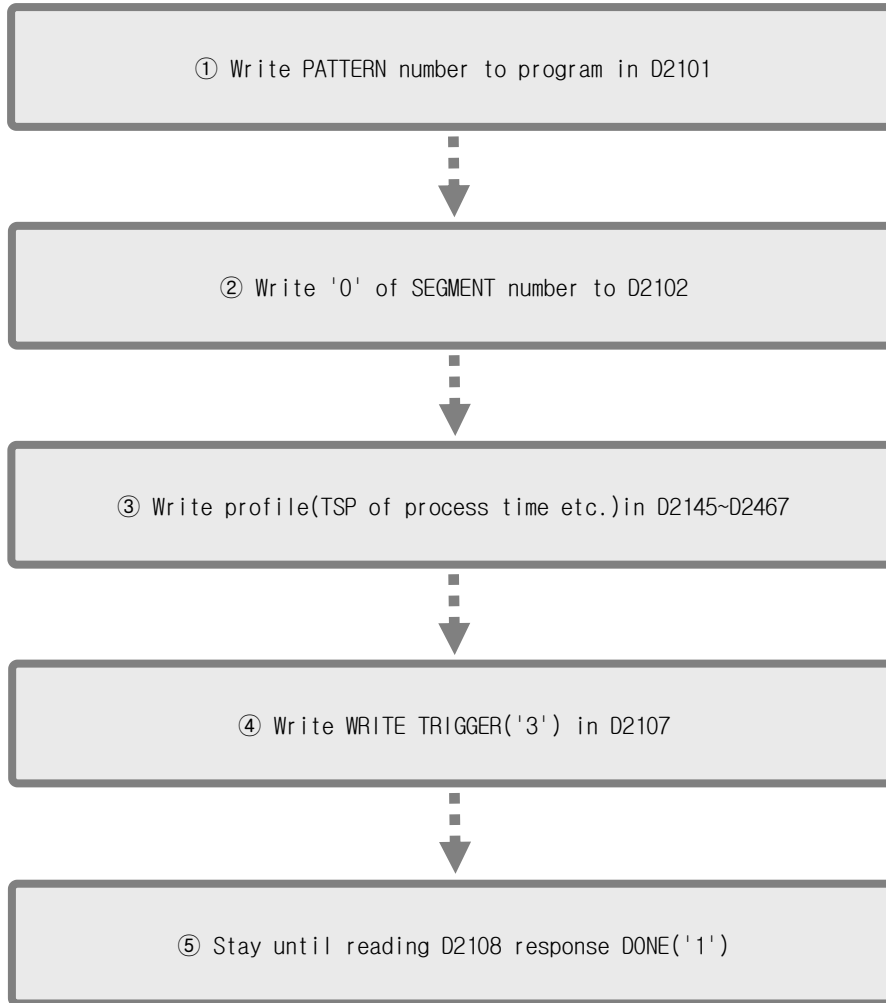

7.17.4 FILE EDIT (PATTERN COPY / DELETE)

► Below describes step to copy pattern.

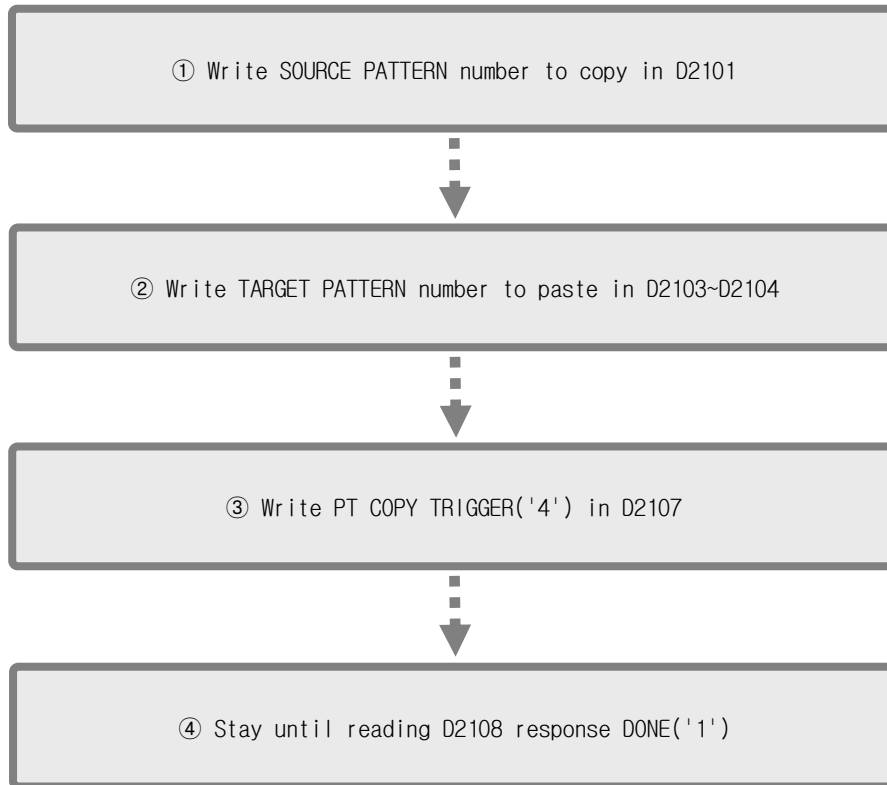

► Below describes step to delete pattern.

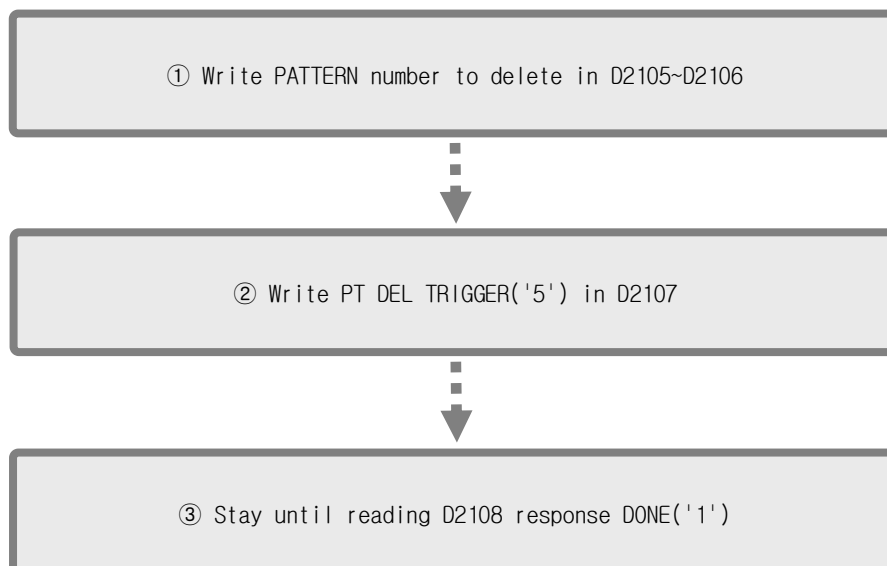

7.18 PATTERN INFO

PATTERN INFO group consists of programmed pattern and segment information parameter D-Register.

■ Programmed pattern and segment information D-Register

D-Reg.	Symbol	Descriptions
D2201	NPT1	The number of programmed SEGMENT in PATTERN no.1
.	.	.
.	.	.
D2280	NPT80	The number of programmed SEGMENT in PATTERN no.80

7.19 FILE

FILE group consists of profile information of programmed pattern parameter D-Register.

■ FILE information D-Register

D-Reg.	Symbol	Descriptions
D2301~D2399	C.TSP1~C.TSP99	SP in reading pattern.
D2501~D2599	C.SRTIME_H1~C.SRTIME_H99	Total operation time (Hour) in reading pattern.
D2601~D2699	C.SRTIME_L1~C.SRTIME_L99	Total operation time (Minute&Second) in reading pattern.
D2701~D2799	C.TS1_1~C.TS1_99	TS1 in reading pattern.
D2801~D2899	C.TS2_1~C.TS2_99	TS2 in reading pattern.
D2901~D2999	C.TS3_1~C.TS3_99	TS3 in reading pattern.
D3001~D3099	C.TS4_1~C.TS4_99	TS4 in reading pattern.
D3101~D3199	C.TS5_1~C.TS5_99	TS5 in reading pattern.
D3201~D3299	C.TS6_1~C.TS6_99	TS6 in reading pattern.
D3301~D3399	C.TS7_1~C.TS7_99	TS7 in reading pattern.
D3401~D3499	C.TS8_1~C.TS8_99	TS8 or AUX in reading pattern.
D3501~D3599	C.SEGAL1_1~C.SEGAL1_99	SEGMENT ALARM1 in reading pattern.
D3601~D3699	C.SEGAL2_1~C.SEGAL2_99	SEGMENT ALARM2 in reading pattern.
D3701~D3799	C.SEGAL3_1~C.SEGAL3_99	SEGMENT ALARM3 in reading pattern.
D3801~D3899	C.SEGAL4_1~C.SEGAL4_99	SEGMENT ALARM4 in reading pattern.
D3901~D3999	C.SEGPID_1~C.SEGPID_99	SEGMENT PID in reading patten.

D-Register 0000 ~ 0599

: Read Only

D-Reg.	PROCESS	FUNCTION	RESERVATION	ON/OFF SIGNAL	INNER SIGNAL	ALARM SIGNAL
	0	100	200	300	400	500
0		SET.PTNO	RESERVE			
1	NPV			T1.LSP	IS1.TYPE	ALM.OP
2		COM.OPMODE	NOW.YEAR	T1.MSP	IS1.BAND	
3	NSP		NOW.MONTH	T1.HSP	IS1.RH	
4		FIX.TSP	NOW.DAY	T1.HDV	IS1.RL	
5	MVOUT		NOW.AMPM	T1.LDV	IS1.DYT	ALM1.TYPE
6		OP.MODE	NOW.HOUR			ALM1.POINT
7	CPIDNO		NOW.MIN		IS2.TYPE	ALM1.H_POINT
8		PWR.MODE	C.YEAR	T2.LSP	IS2.BAND	ALM1.L_POINT
9			C.MONTH	T2.MSP	IS2.RH	ALM1.HYS
10	NOW.STS	SLOPE	C.DAY	T2.HSP	IS2.RL	ALM1.DYT
11			C.AMPM	T2.HDV	IS2.DYT	
12	IS.STS	FUZZY	C.HOUR	T2.LDV		ALM2.TYPE
13			C.MIN		IS3.TYPE	ALM2.POINT
14	TS.STS	TIME.OP	R.YEAR		IS3.BAND	ALM2.H_POINT
15		TIME.OP_H	R.MONTH	T3.LSP	IS3.RH	ALM2.L_POINT
16	ALM.STS	TIME.OP_M	R.DAY	T3.MSP	IS3.RL	ALM2.HYS
17			R.AMPM	T3.HSP	IS3.DYT	ALM2.DYT
18	SEGALM.STS		R.HOUR	T3.HDV		
19			R.MIN	T3.LDV	IS4.TYPE	ALM3.TYPE
20	ONOFF.STS				IS4.BAND	ALM3.POINT
21		KEYLOCK			IS4.RH	ALM3.H_POINT
22	ADERR.STS			T4.LSP	IS4.RL	ALM3.L_POINT
23				T4.MSP	IS4.DYT	ALM3.HYS
24	DOCTR.STS			T4.HSP		ALM3.DYT
25				T4.HDV	IS5.TYPE	
26	CTR.STS	DRAW.CYCLE		T4.LDV	IS5.BAND	ALM4.TYPE
27		PV.GRP_RECORD			IS5.RH	ALM4.POINT
28	DO.STS1				IS5.RL	ALM4.H_POINT
29	DO.STS2			T5.LSP	IS5.DYT	ALM4.L_POINT
30	DI.DATA	REC.OP		T5.MSP		ALM4.HYS
31	SYS.STS	REC.CYCLE		T5.HSP	IS6.TYPE	ALM4.DYT
32		BACK.ITEM		T5.HDV	IS6.BAND	
33		BACK.DIR		T5.LDV	IS6.RH	
34	RUN.TIME_H				IS6.RL	
35	RUN.TIME_M				IS6.DYT	
36	RUN.TIME_S	AT		T6.LSP		
37				T6.MSP	IS7.TYPE	
38				T6.HSP	IS7.BAND	
39				T6.HDV	IS7.RH	
40	RUN.PTNO	WAIT.USE		T6.LDV	IS7.RL	
41	RUN.SEGNO				IS7.DYT	
42		WAIT_ZONE				
43					IS8.TYPE	
44	NOW.PT.RPT	WAIT.TIME			IS8.BAND	
45	TOTAL.PT.RPT				IS8.RH	
46		WAIT.METHOD			IS8.RL	
47					IS8.DYT	
48	NOW.SEG.RPT					
49	TOTAL.SEG.RPT					

D-Reg.	PROCESS	FUNCTION	RESERVATION	ON/OFF SIGNAL	INNER SIGNAL	ALARM SIGNAL
	0	100	200	300	400	500
50		PV.FONT				
51		BUZ.ONOFF				
52	NOW.SEGTM_H	LIGHT.OFFTM				
53	NOW.SEGTM_L					
54	TOTAL.SEGTM_H					
55	TOTAL.SEGTM_L					
56						
57						
58						
59						
60	PREV.TSP	UTAG_USING	TIME_VALID			
61	NOW.TSP	UTAG_NAME1	START_YEAR			
62		UTAG_NAME2	START_MON			
63		UTAG_NAME3	START_DAY			
64			START_HOUR			
65	USED PATTERN		START_MIN			
66	USED SEGMENT		END_YEAR			
67			END_MON			
68			END_DAY			
69			END_HOUR			
70			END_MIN			
71	CH1.HMVOUT					
72	CH2.HMVOUT					
73	CH1.CMVOUT					
74	CH2.CMVOUT					
75						
76						
77						
78						
79						
80						
81						
82						
83						
84						
85						
86						
87						
88						
89						
90						
91						
92						
93						
94						
95						
96						
97						
98						
99						

D-Register 0600 ~ 1199

D-Reg.	SEG ALARM SIGNAL	TIME SIGNAL	COMMUNICATION	PICTURE	PID1	PID2
	600	700	800	900	1000	1100
0						
1	SA1.TYPE	TS2DYTM_H	COM2.PROTOCOL	VIEW.ROTATE	RP1	1_P
2	SA1.POINT	TS2DYTM_L	COM2.BPS	R.ST_TIME	RP2	1_I
3	SA1.H_POINT	TS2KPTM_H	COM2.PARITY	R.INT_TIME	RP3	1_D
4	SA1.L_POINT	TS2KPTM_L	COM2.STOP.BIT		RP4	1_OH
5	SA1.HYS	TS3DYTM_H	COM2.DATA.LENGTH			1_OL
6	SA1.DYT	TS3DYTM_L	COM2.ADDRESS			1_MR
7	SA2.TYPE	TS3KPTM_H	COM2.RESPONSE			1_HHYS
8	SA2.POINT	TS3KPTM_L	COM4.BPS			1_LHYS
9	SA2.H_POINT	TS4DYTM_H	SYNC.MST		RHYS	2_P
10	SA2.L_POINT	TS4DYTM_L			RDEV	2_I
11	SA2.HYS	TS4KPTM_H				2_D
12	SA2.DYT	TS4KPTM_L				2_OH
13	SA3.TYPE	TS5DYTM_H			CMOD	2_OL
14	SA3.POINT	TS5DYTM_L				2_MR
15	SA3.H_POINT	TS5KPTM_H			AT.POINT	2_HHYS
16	SA3.L_POINT	TS5KPTM_L				2_LHYS
17	SA3.HYS	TS6DYTM_H			AT.DISPLAY	3_P
18	SA3.DYT	TS6DYTM_L				3_I
19	SA4.TYPE	TS6KPTM_H			PID.OPMODE	3_D
20	SA4.POINT	TS6KPTM_L				3_OH
21	SA4.H_POINT	TS7DYTM_H			PID.APP	3_OL
22	SA4.L_POINT	TS7DYTM_L				3_MR
23	SA4.HYS	TS7KPTM_H				3_HHYS
24	SA4.DYT	TS7KPTM_L				3_LHYS
25	SA5.TYPE	TS8DYTM_H			1._CP	4_P
26	SA5.POINT	TS8DYTM_L			1._CI	4_I
27	SA5.H_POINT	TS8KPTM_H			1._CD	4_D
28	SA5.L_POINT	TS8KPTM_L			2._CP	4_OH
29	SA5.HYS	TS9DYTM_H			2._CI	4_OL
30	SA5.DYT	TS9DYTM_L			2._CD	4_MR
31	SA6.TYPE	TS9KPTM_H			3._CP	4_HHYS
32	SA6.POINT	TS9KPTM_L			3._CI	4_LHYS
33	SA6.H_POINT	TS10DYTM_H			3._CD	5_P
34	SA6.L_POINT	TS10DYTM_L			4._CP	5_I
35	SA6.HYS	TS10KPTM_H			4._CI	5_D
36	SA6.DYT	TS10KPTM_L			4._CD	5_OH
37	SA7.TYPE	TS11DYTM_H			5._CP	5_OL
38	SA7.POINT	TS11DYTM_L			5._CI	5_MR
39	SA7.H_POINT	TS11KPTM_H			5._CD	5_HHYS
40	SA7.L_POINT	TS11KPTM_L			6._CP	5_LHYS
41	SA7.HYS	TS12DYTM_H			6._CI	6_P
42	SA7.DYT	TS12DYTM_L			6._CD	6_I
43	SA8.TYPE	TS12KPTM_H				6_D
44	SA8.POINT	TS12KPTM_L				6_OH
45	SA8.H_POINT	TS13DYTM_H				6_OL
46	SA8.L_POINT	TS13DYTM_L				6_MR
47	SA8.HYS	TS13KPTM_H				6_HHYS
48	SA8.DYT	TS13KPTM_L				6_LHYS
49		TS14DYTM_H				

D-Reg.	SEG ALARM SIGNAL	TIME SIGNAL	COMMUNICATION	PICTURE	PID1	PID2
	600	700	800	900	1000	1100
50		TS14DYTM_L				
51		TS14KPTM_H				
52		TS14KPTM_L				
53		TS15DYTM_H				
54		TS15DYTM_L				
55		TS15KPTM_H				
56		TS15KPTM_L				
57		TS16DYTM_H				
58		TS16DYTM_L				
59		TS16KPTM_H				
60		TS16KPTM_L				
61		TS17DYTM_H				
62		TS17DYTM_L				
63		TS17KPTM_H				
64		TS17KPTM_L				
65		TS18DYTM_H			1.DB	
66		TS18DYTM_L			2.DB	
67		TS18KPTM_H			3.DB	
68		TS18KPTM_L			4.DB	
69		TS19DYTM_H			5.DB	
70		TS19DYTM_L			6.DB	
71		TS19KPTM_H				
72		TS19KPTM_L				
73		TS20DYTM_H				
74		TS20DYTM_L				
75		TS20KPTM_H				
76		TS20KPTM_L				
77						
78						
79					CH1HCHYS	
80					CH1HCHYS	
81						
82					1.CH1_C0H	
83					2.CH1_C0H	
84					3.CH1_C0H	
85					4.CH1_C0H	
86					5.CH1_C0H	
87					6.CH1_C0H	
88					1.CH2_C0H	
89					2.CH2_C0H	
90					3.CH2_C0H	
91					4.CH2_C0H	
92					5.CH2_C0H	
93					6.CH2_C0H	
94						
95						
96						
97						
98						
99						

D-Register 1200 ~ 1799

D-Reg.	INPUT	OUTPUT	DO CONFIG1	DO CONFIG2	DI CONFIG1	DI CONFIG2
	1200	1300	1400	1500	1600	1700
0						
1	SENGP	OUT1.TYPE	IS1.RLY	RUN.RLY	DISP.METHOD	D11.NAME1
2	SENTP	OUT2.TYPE	IS2.RLY	RUN.DYT	BUZ.TIME	D11.NAME2
3	UNIT	OUT3.TYPE	IS3.RLY		DIDET.TIME	D11.NAME3
4	DP	OUT4.TYPE	IS4.RLY			D11.NAME4
5	TCSL		IS5.RLY	SOPN.RLY		D11.NAME5
6	SOPN.SEL		IS6.RLY	SOPN.KPT	D11.OP_MODE	D11.NAME6
7	INRH		IS7.RLY		D12.OP_MODE	D11.NAME7
8	INRL		IS8.RLY		D13.OP_MODE	D11.NAME8
9	BIAS	DIR		WAIT.RLY	D14.OP_MODE	D11.NAME9
10	INFL			WAIT.KPT		D11.NAME10
11		ARW				D11.NAME11
12	INSH					D11.NAME12
13	INSL	UPOPR		UP.RLY		D12.NAME1
14		DNOPR		UP.DEV		D12.NAME2
15						D12.NAME3
16						D12.NAME4
17		HCT	TS1.RLY	SOAK.RLY		D12.NAME5
18			TS2.RLY	SOAK.KPT	D11.OP	D12.NAME6
19		HPO	TS3.RLY		D11.DVT	D12.NAME7
20			TS4.RLY		D12.OP	D12.NAME8
21		HATG	TS5.RLY	DOWN.RLY	D12.DVT	D12.NAME9
22			TS6.RLY	DOWN.DEV	D13.OP	D12.NAME10
23			TS7.RLY		D13.DVT	D12.NAME11
24			TS8.RLY		D14.OP	D12.NAME12
25		RETT		FEND.RLY	D14.DVT	D13.NAME1
26				FEND.KPT	D15.OP	D13.NAME2
27		RETH			D15.DVT	D13.NAME3
28		RETL			D16.OP	D13.NAME4
29	BP1.DDV			PTEND.RLY	D16.DVT	D13.NAME5
30	BP2.DDV			PTEND.KPT	D17.OP	D13.NAME6
31	BP3.DDV				D17.DVT	D13.NAME7
32	BP4.DDV				D18.OP	D13.NAME8
33	BP5.DDV	CCT	ALM1.RLY	1REF.RLY	D18.DVT	D13.NAME9
34	BP6.DDV		ALM2.RLY	1REF.DYT	D19.OP	D13.NAME10
35	BP7.DDV	CPO	ALM3.RLY	2REF.RLY	D19.DVT	D13.NAME11
36	BP8.DDV		ALM4.RLY	2REF.DYT	D110.OP	D13.NAME12
37	BP1.DPV	CATG			D110.DVT	D14.NAME1
38	BP2.DPV				D111.OP	D14.NAME2
39	BP3.DPV				D111.DVT	D14.NAME3
40	BP4.DPV				D112.OP	D14.NAME4
41	BP5.DPV	OUT1.MODE	SA1.RLY	ERROR.RLY	D112.DVT	D14.NAME5
42	BP6.DPV	OUT2.MODE	SA2.RLY	ERROR.KPT	D113.OP	D14.NAME6
43	BP7.DPV	OUT3.MODE	SA3.RLY		D113.DVT	D14.NAME7
44	BP8.DPV	OUT4.MODE	SA4.RLY		D114.OP	D14.NAME8
45				UKEY.RLY	D114.DVT	D14.NAME9
46				D11.RLY	D115.OP	D14.NAME10
47		OUT3.SCRTYPE		D12.RLY	D115.DVT	D14.NAME11
48		OUT4.SCRTYPE		D13.RLY	D116.OP	D14.NAME12
49			T1.RLY	D14.RLY	D116.DVT	D15.NAME1

D-Reg.	INPUT	OUTPUT	DO CONFIG1	DO CONFIG2	DI CONFIG1	DI CONFIG2
	1200	1300	1400	1500	1600	1700
50			T1.DYT	D15.RLY		D15.NAME2
51			T2.RLY	D16.RLY		D15.NAME3
52			T2.DYT	D17.RLY	D11.DETECT	D15.NAME4
53			T3.RLY	D18.RLY	D12.DETECT	D15.NAME5
54			T3.DYT	D19.RLY	D13.DETECT	D15.NAME6
55			T4.RLY	D110.RLY	D14.DETECT	D15.NAME7
56			T4.DYT	D111.RLY	D15.DETECT	D15.NAME8
57			T5.RLY	D112.RLY	D16.DETECT	D15.NAME9
58			T5.DYT	D113.RLY	D17.DETECT	D15.NAME10
59			T6.RLY	D114.RLY	D18.DETECT	D15.NAME11
60			T6.DYT	D115.RLY	D19.DETECT	D15.NAME12
61			T7.RLY	D116.RLY	D110.DETECT	D16.NAME1
62			T7.DYT	USER.RLY1	D111.DETECT	D16.NAME2
63				USER.RLY2	D112.DETECT	D16.NAME3
64				USER.RLY3	D113.DETECT	D16.NAME4
65				USER.RLY4	D114.DETECT	D16.NAME5
66				USER.RLY5	D115.DETECT	D16.NAME6
67				USER.RLY6	D116.DETECT	D16.NAME7
68				USER.RLY7		D16.NAME8
69				USER.RLY8		D16.NAME9
70				USER.RLY9	LOG. OUTRLY1	D16.NAME10
71	UNITNAME1			USER.RLY10	LOG. SRCLRYa1	D16.NAME11
72	UNITNAME2			USER.RLY11	LOG. SRCLRYb1	D16.NAME12
73				USER.RLY12	LOG. OPERAND1	D17.NAME1
74				USER.RLY_ON/OFF	LOG. OUTRLY2	D17.NAME2
75				FEND.DLT	LOG. SRCLRYa2	D17.NAME3
76				PTEND.DLT	LOG. SRCLRYb2	D17.NAME4
77					LOG. OPERAND2	D17.NAME5
78					LOG. OUTRLY3	D17.NAME6
79					LOG. SRCLRYa3	D17.NAME7
80					LOG. SRCLRYb3	D17.NAME8
81				FIXTIMER.RLY	LOG. OPERAND3	D17.NAME9
82				FIXTIMER.DEV		D17.NAME10
83				FIXTIMER.DLY		D17.NAME11
84				FIXTIMER.OPT		D17.NAME12
85						D18.NAME1
86						D18.NAME2
87						D18.NAME3
88						D18.NAME4
89						D18.NAME5
90						D18.NAME6
91				UP.DEVSEL		D18.NAME7
92				DN.DEVSEL		D18.NAME8
93						D18.NAME9
94						D18.NAME10
95						D18.NAME11
96						D18.NAME12
97						
98						
99						

D-Register 1800 ~ 2399

D-Reg.	DI CONFIG3	INITIAL1	INITIAL2	PROGRAM	PATTERN INFO	FILE1
	1800	1900	2000	2100	2200	2300
0						
1	D19.NAME1	LANGUAGE	LAMP_IS1	COM_PTNO	NPT1	C.TSP1
2	D19.NAME2	DISP.MODE	LAMP_IS2	COM_SEGNO	NPT2	C.TSP2
3	D19.NAME3	UKEY.USE	LAMP_IS3	PTCOPY_START	NPT3	C.TSP3
4	D19.NAME4		LAMP_IS4	PTCOPY_END	NPT4	C.TSP4
5	D19.NAME5		LAMP_IS5	PTDEL_START	NPT5	C.TSP5
6	D19.NAME6	INFORM1.NAME1	LAMP_IS6	PTDEL_END	NPT6	C.TSP6
7	D19.NAME7	INFORM1.NAME2	LAMP_IS7	TRIGGER	NPT7	C.TSP7
8	D19.NAME8	INFORM1.NAME3	LAMP_IS8	ANSWER	NPT8	C.TSP8
9	D19.NAME9	INFORM1.NAME4	LAMP_TS1		NPT9	C.TSP9
10	D19.NAME10	INFORM1.NAME5	LAMP_TS2		NPT10	C.TSP10
11	D19.NAME11	INFORM1.NAME6	LAMP_TS3	PATTERN_NAME1	NPT11	C.TSP11
12	D19.NAME12	INFORM1.NAME7	LAMP_TS4	PATTERN_NAME2	NPT12	C.TSP12
13	D110.NAME1	INFORM1.NAME8	LAMP_TS5	PATTERN_NAME3	NPT13	C.TSP13
14	D110.NAME2	INFORM1.NAME9	LAMP_TS6	PATTERN_NAME4	NPT14	C.TSP14
15	D110.NAME3	INFORM1.NAME10	LAMP_TS7	PATTERN_NAME5	NPT15	C.TSP15
16	D110.NAME4	INFORM1.NAME11	LAMP_TS8	PATTERN_NAME6	NPT16	C.TSP16
17	D110.NAME5	INFORM1.NAME12	LAMP_AL1	PATTERN_NAME7	NPT17	C.TSP17
18	D110.NAME6	INFORM1.NAME13	LAMP_AL2	PATTERN_NAME8	NPT18	C.TSP18
19	D110.NAME7	INFORM2.NAME1	LAMP_AL3	PATTERN_NAME9	NPT19	C.TSP19
20	D110.NAME8	INFORM2.NAME2	LAMP_AL4	PATTERN_NAME10	NPT20	C.TSP20
21	D110.NAME9	INFORM2.NAME3	LAMP_SAL1	PATTERN_NAME11	NPT21	C.TSP21
22	D110.NAME10	INFORM2.NAME4	LAMP_SAL2	PATTERN_NAME12	NPT22	C.TSP22
23	D110.NAME11	INFORM2.NAME5	LAMP_SAL3		NPT23	C.TSP23
24	D110.NAME12	INFORM2.NAME6	LAMP_SAL4		NPT24	C.TSP24
25	D111.NAME1	INFORM2.NAME7	LAMP_T1		NPT25	C.TSP25
26	D111.NAME2	INFORM2.NAME8	LAMP_T2	TSP	NPT26	C.TSP26
27	D111.NAME3	INFORM2.NAME9	LAMP_T3	SEG.TIME_H	NPT27	C.TSP27
28	D111.NAME4	INFORM2.NAME10	LAMP_T4	SEG.TIME_L	NPT28	C.TSP28
29	D111.NAME5	INFORM2.NAME11	LAMP_T5	TS1	NPT29	C.TSP29
30	D111.NAME6	INFORM2.NAME12	LAMP_T6	TS2	NPT30	C.TSP30
31	D111.NAME7	INFORM2.NAME13	LAMP_T7	TS3	NPT31	C.TSP31
32	D111.NAME8	INFORM3.NAME1	LAMP_RUN	TS4	NPT32	C.TSP32
33	D111.NAME9	INFORM3.NAME2	LAMP_1REF	TS5	NPT33	C.TSP33
34	D111.NAME10	INFORM3.NAME3	LAMP_2REF	TS6	NPT34	C.TSP34
35	D111.NAME11	INFORM3.NAME4	LAMP_SD	TS7	NPT35	C.TSP35
36	D111.NAME12	INFORM3.NAME5	LAMP_D11	TS8	NPT36	C.TSP36
37	D112.NAME1	INFORM3.NAME6	LAMP_D12	SEGAL1	NPT37	C.TSP37
38	D112.NAME2	INFORM3.NAME7	LAMP_D13	SEGAL2	NPT38	C.TSP38
39	D112.NAME3	INFORM3.NAME8	LAMP_D14	SEGAL3	NPT39	C.TSP39
40	D112.NAME4	INFORM3.NAME9	LAMP_D15	SEGAL4	NPT40	C.TSP40
41	D112.NAME5	INFORM3.NAME10	LAMP_D16	SEG_PID	NPT41	C.TSP41
42	D112.NAME6	INFORM3.NAME11	LAMP_D17	AUX_OUT	NPT42	C.TSP42
43	D112.NAME7	INFORM3.NAME12	LAMP_D18		NPT43	C.TSP43
44	D112.NAME8	INFORM3.NAME13	LAMP_D19		NPT44	C.TSP44
45	D112.NAME9		LAMP_D110	START.CODE	NPT45	C.TSP45
46	D112.NAME10		LAMP_D111	START.SP	NPT46	C.TSP46
47	D112.NAME11		LAMP_D112		NPT47	C.TSP47
48	D112.NAME12		LAMP_D113		NPT48	C.TSP48
49	D113.NAME1		LAMP_D114		NPT49	C.TSP49

D-Reg.	DI CONFIG3	INITIAL1	INITIAL2	PROGRAM	PATTERN INFO	FILE1
	1800	1900	2000	2100	2200	2300
50	DI13.NAME2		LAMP_ DI15	PT.RPT	NPT50	C.TSP50
51	DI13.NAME3		LAMP_ DI16	PT.EMOD	NPT51	C.TSP51
52	DI13.NAME4			LINK.PT	NPT52	C.TSP52
53	DI13.NAME5				NPT53	C.TSP53
54	DI13.NAME6				NPT54	C.TSP54
55	DI13.NAME7				NPT55	C.TSP55
56	DI13.NAME8			SEG_RPT.S1	NPT56	C.TSP56
57	DI13.NAME9			SEG_RPT.E1	NPT57	C.TSP57
58	DI13.NAME10			SEG_RPT.C1	NPT58	C.TSP58
59	DI13.NAME11			SEG_RPT.S2	NPT59	C.TSP59
60	DI13.NAME12			SEG_RPT.E2	NPT60	C.TSP60
61	DI14.NAME1			SEG_RPT.C2	NPT61	C.TSP61
62	DI14.NAME2			SEG_RPT.S3	NPT62	C.TSP62
63	DI14.NAME3			SEG_RPT.E3	NPT63	C.TSP63
64	DI14.NAME4			SEG_RPT.C3	NPT64	C.TSP64
65	DI14.NAME5			SEG_RPT.S4	NPT65	C.TSP65
66	DI14.NAME6			SEG_RPT.E4	NPT66	C.TSP66
67	DI14.NAME7			SEG_RPT.C4	NPT67	C.TSP67
68	DI14.NAME8				NPT68	C.TSP68
69	DI14.NAME9				NPT69	C.TSP69
70	DI14.NAME10				NPT70	C.TSP70
71	DI14.NAME11				NPT71	C.TSP71
72	DI14.NAME12				NPT72	C.TSP72
73	DI15.NAME1				NPT73	C.TSP73
74	DI15.NAME2				NPT74	C.TSP74
75	DI15.NAME3				NPT75	C.TSP75
76	DI15.NAME4				NPT76	C.TSP76
77	DI15.NAME5				NPT77	C.TSP77
78	DI15.NAME6				NPT78	C.TSP78
79	DI15.NAME7				NPT79	C.TSP79
80	DI15.NAME8				NPT80	C.TSP80
81	DI15.NAME9					C.TSP81
82	DI15.NAME10					C.TSP82
83	DI15.NAME11					C.TSP83
84	DI15.NAME12					C.TSP84
85	DI16.NAME1					C.TSP85
86	DI16.NAME2					C.TSP86
87	DI16.NAME3					C.TSP87
88	DI16.NAME4					C.TSP88
89	DI16.NAME5					C.TSP89
90	DI16.NAME6					C.TSP90
91	DI16.NAME7					C.TSP91
92	DI16.NAME8					C.TSP92
93	DI16.NAME9					C.TSP93
94	DI16.NAME10					C.TSP94
95	DI16.NAME11					C.TSP95
96	DI16.NAME12					C.TSP96
97						C.TSP97
98						C.TSP98
99						C.TSP99

D-Register 2400 ~ 2999

D-Reg.	FILE2	FILE3	FILE4	FILE5	FILE6	FILE7
	2400	2500	2600	2700	2800	2900
0						
1		C.SRTIME_H1	C.SRTIME_L1	C.TS1_1	C.TS2_1	C.TS3_1
2		C.SRTIME_H2	C.SRTIME_L2	C.TS1_2	C.TS2_2	C.TS3_2
3		C.SRTIME_H3	C.SRTIME_L3	C.TS1_3	C.TS2_3	C.TS3_3
4		C.SRTIME_H4	C.SRTIME_L4	C.TS1_4	C.TS2_4	C.TS3_4
5		C.SRTIME_H5	C.SRTIME_L5	C.TS1_5	C.TS2_5	C.TS3_5
6		C.SRTIME_H6	C.SRTIME_L6	C.TS1_6	C.TS2_6	C.TS3_6
7		C.SRTIME_H7	C.SRTIME_L7	C.TS1_7	C.TS2_7	C.TS3_7
8		C.SRTIME_H8	C.SRTIME_L8	C.TS1_8	C.TS2_8	C.TS3_8
9		C.SRTIME_H9	C.SRTIME_L9	C.TS1_9	C.TS2_9	C.TS3_9
10		C.SRTIME_H10	C.SRTIME_L10	C.TS1_10	C.TS2_10	C.TS3_10
11		C.SRTIME_H11	C.SRTIME_L11	C.TS1_11	C.TS2_11	C.TS3_11
12		C.SRTIME_H12	C.SRTIME_L12	C.TS1_12	C.TS2_12	C.TS3_12
13		C.SRTIME_H13	C.SRTIME_L13	C.TS1_13	C.TS2_13	C.TS3_13
14		C.SRTIME_H14	C.SRTIME_L14	C.TS1_14	C.TS2_14	C.TS3_14
15		C.SRTIME_H15	C.SRTIME_L15	C.TS1_15	C.TS2_15	C.TS3_15
16		C.SRTIME_H16	C.SRTIME_L16	C.TS1_16	C.TS2_16	C.TS3_16
17		C.SRTIME_H17	C.SRTIME_L17	C.TS1_17	C.TS2_17	C.TS3_17
18		C.SRTIME_H18	C.SRTIME_L18	C.TS1_18	C.TS2_18	C.TS3_18
19		C.SRTIME_H19	C.SRTIME_L19	C.TS1_19	C.TS2_19	C.TS3_19
20		C.SRTIME_H20	C.SRTIME_L20	C.TS1_20	C.TS2_20	C.TS3_20
21		C.SRTIME_H21	C.SRTIME_L21	C.TS1_21	C.TS2_21	C.TS3_21
22		C.SRTIME_H22	C.SRTIME_L22	C.TS1_22	C.TS2_22	C.TS3_22
23		C.SRTIME_H23	C.SRTIME_L23	C.TS1_23	C.TS2_23	C.TS3_23
24		C.SRTIME_H24	C.SRTIME_L24	C.TS1_24	C.TS2_24	C.TS3_24
25		C.SRTIME_H25	C.SRTIME_L25	C.TS1_25	C.TS2_25	C.TS3_25
26		C.SRTIME_H26	C.SRTIME_L26	C.TS1_26	C.TS2_26	C.TS3_26
27		C.SRTIME_H27	C.SRTIME_L27	C.TS1_27	C.TS2_27	C.TS3_27
28		C.SRTIME_H28	C.SRTIME_L28	C.TS1_28	C.TS2_28	C.TS3_28
29		C.SRTIME_H29	C.SRTIME_L29	C.TS1_29	C.TS2_29	C.TS3_29
30		C.SRTIME_H30	C.SRTIME_L30	C.TS1_30	C.TS2_30	C.TS3_30
31		C.SRTIME_H31	C.SRTIME_L31	C.TS1_31	C.TS2_31	C.TS3_31
32		C.SRTIME_H32	C.SRTIME_L32	C.TS1_32	C.TS2_32	C.TS3_32
33		C.SRTIME_H33	C.SRTIME_L33	C.TS1_33	C.TS2_33	C.TS3_33
34		C.SRTIME_H34	C.SRTIME_L34	C.TS1_34	C.TS2_34	C.TS3_34
35		C.SRTIME_H35	C.SRTIME_L35	C.TS1_35	C.TS2_35	C.TS3_35
36		C.SRTIME_H36	C.SRTIME_L36	C.TS1_36	C.TS2_36	C.TS3_36
37		C.SRTIME_H37	C.SRTIME_L37	C.TS1_37	C.TS2_37	C.TS3_37
38		C.SRTIME_H38	C.SRTIME_L38	C.TS1_38	C.TS2_38	C.TS3_38
39		C.SRTIME_H39	C.SRTIME_L39	C.TS1_39	C.TS2_39	C.TS3_39
40		C.SRTIME_H40	C.SRTIME_L40	C.TS1_40	C.TS2_40	C.TS3_40
41		C.SRTIME_H41	C.SRTIME_L41	C.TS1_41	C.TS2_41	C.TS3_41
42		C.SRTIME_H42	C.SRTIME_L42	C.TS1_42	C.TS2_42	C.TS3_42
43		C.SRTIME_H43	C.SRTIME_L43	C.TS1_43	C.TS2_43	C.TS3_43
44		C.SRTIME_H44	C.SRTIME_L44	C.TS1_44	C.TS2_44	C.TS3_44
45		C.SRTIME_H45	C.SRTIME_L45	C.TS1_45	C.TS2_45	C.TS3_45
46		C.SRTIME_H46	C.SRTIME_L46	C.TS1_46	C.TS2_46	C.TS3_46
47		C.SRTIME_H47	C.SRTIME_L47	C.TS1_47	C.TS2_47	C.TS3_47
48		C.SRTIME_H48	C.SRTIME_L48	C.TS1_48	C.TS2_48	C.TS3_48
49		C.SRTIME_H49	C.SRTIME_L49	C.TS1_49	C.TS2_49	C.TS3_49

D-Reg.	FILE2	FILE3	FILE4	FILE5	FILE6	FILE7
	2400	2500	2600	2700	2800	2900
50		C.SRTIME_H50	C.SRTIME_L50	C.TS1_50	C.TS2_50	C.TS3_50
51		C.SRTIME_H51	C.SRTIME_L51	C.TS1_51	C.TS2_51	C.TS3_51
52		C.SRTIME_H52	C.SRTIME_L52	C.TS1_52	C.TS2_52	C.TS3_52
53		C.SRTIME_H53	C.SRTIME_L53	C.TS1_53	C.TS2_53	C.TS3_53
54		C.SRTIME_H54	C.SRTIME_L54	C.TS1_54	C.TS2_54	C.TS3_54
55		C.SRTIME_H55	C.SRTIME_L55	C.TS1_55	C.TS2_55	C.TS3_55
56		C.SRTIME_H56	C.SRTIME_L56	C.TS1_56	C.TS2_56	C.TS3_56
57		C.SRTIME_H57	C.SRTIME_L57	C.TS1_57	C.TS2_57	C.TS3_57
58		C.SRTIME_H58	C.SRTIME_L58	C.TS1_58	C.TS2_58	C.TS3_58
59		C.SRTIME_H59	C.SRTIME_L59	C.TS1_59	C.TS2_59	C.TS3_59
60		C.SRTIME_H60	C.SRTIME_L60	C.TS1_60	C.TS2_60	C.TS3_60
61		C.SRTIME_H61	C.SRTIME_L61	C.TS1_61	C.TS2_61	C.TS3_61
62		C.SRTIME_H62	C.SRTIME_L62	C.TS1_62	C.TS2_62	C.TS3_62
63		C.SRTIME_H63	C.SRTIME_L63	C.TS1_63	C.TS2_63	C.TS3_63
64		C.SRTIME_H64	C.SRTIME_L64	C.TS1_64	C.TS2_64	C.TS3_64
65		C.SRTIME_H65	C.SRTIME_L65	C.TS1_65	C.TS2_65	C.TS3_65
66		C.SRTIME_H66	C.SRTIME_L66	C.TS1_66	C.TS2_66	C.TS3_66
67		C.SRTIME_H67	C.SRTIME_L67	C.TS1_67	C.TS2_67	C.TS3_67
68		C.SRTIME_H68	C.SRTIME_L68	C.TS1_68	C.TS2_68	C.TS3_68
69		C.SRTIME_H69	C.SRTIME_L69	C.TS1_69	C.TS2_69	C.TS3_69
70		C.SRTIME_H70	C.SRTIME_L70	C.TS1_70	C.TS2_70	C.TS3_70
71		C.SRTIME_H71	C.SRTIME_L71	C.TS1_71	C.TS2_71	C.TS3_71
72		C.SRTIME_H72	C.SRTIME_L72	C.TS1_72	C.TS2_72	C.TS3_72
73		C.SRTIME_H73	C.SRTIME_L73	C.TS1_73	C.TS2_73	C.TS3_73
74		C.SRTIME_H74	C.SRTIME_L74	C.TS1_74	C.TS2_74	C.TS3_74
75		C.SRTIME_H75	C.SRTIME_L75	C.TS1_75	C.TS2_75	C.TS3_75
76		C.SRTIME_H76	C.SRTIME_L76	C.TS1_76	C.TS2_76	C.TS3_76
77		C.SRTIME_H77	C.SRTIME_L77	C.TS1_77	C.TS2_77	C.TS3_77
78		C.SRTIME_H78	C.SRTIME_L78	C.TS1_78	C.TS2_78	C.TS3_78
79		C.SRTIME_H79	C.SRTIME_L79	C.TS1_79	C.TS2_79	C.TS3_79
80		C.SRTIME_H80	C.SRTIME_L80	C.TS1_80	C.TS2_80	C.TS3_80
81		C.SRTIME_H81	C.SRTIME_L81	C.TS1_81	C.TS2_81	C.TS3_81
82		C.SRTIME_H82	C.SRTIME_L82	C.TS1_82	C.TS2_82	C.TS3_82
83		C.SRTIME_H83	C.SRTIME_L83	C.TS1_83	C.TS2_83	C.TS3_83
84		C.SRTIME_H84	C.SRTIME_L84	C.TS1_84	C.TS2_84	C.TS3_84
85		C.SRTIME_H85	C.SRTIME_L85	C.TS1_85	C.TS2_85	C.TS3_85
86		C.SRTIME_H86	C.SRTIME_L86	C.TS1_86	C.TS2_86	C.TS3_86
87		C.SRTIME_H87	C.SRTIME_L87	C.TS1_87	C.TS2_87	C.TS3_87
88		C.SRTIME_H88	C.SRTIME_L88	C.TS1_88	C.TS2_88	C.TS3_88
89		C.SRTIME_H89	C.SRTIME_L89	C.TS1_89	C.TS2_89	C.TS3_89
90		C.SRTIME_H90	C.SRTIME_L90	C.TS1_90	C.TS2_90	C.TS3_90
91		C.SRTIME_H91	C.SRTIME_L91	C.TS1_91	C.TS2_91	C.TS3_91
92		C.SRTIME_H92	C.SRTIME_L92	C.TS1_92	C.TS2_92	C.TS3_92
93		C.SRTIME_H93	C.SRTIME_L93	C.TS1_93	C.TS2_93	C.TS3_93
94		C.SRTIME_H94	C.SRTIME_L94	C.TS1_94	C.TS2_94	C.TS3_94
95		C.SRTIME_H95	C.SRTIME_L95	C.TS1_95	C.TS2_95	C.TS3_95
96		C.SRTIME_H96	C.SRTIME_L96	C.TS1_96	C.TS2_96	C.TS3_96
97		C.SRTIME_H97	C.SRTIME_L97	C.TS1_97	C.TS2_97	C.TS3_97
98		C.SRTIME_H98	C.SRTIME_L98	C.TS1_98	C.TS2_98	C.TS3_98
99		C.SRTIME_H99	C.SRTIME_L99	C.TS1_99	C.TS2_99	C.TS3_99

D-Register 3000 ~ 3599

D-Reg.	FILE8	FILE9	FILE10	FILE11	FILE12	FILE13
	3000	3100	3200	3300	3400	3500
0						
1	C.TS4_1	C.TS5_1	C.TS6_1	C.TS7_1	C.TS8_1	C.SEGAL1_1
2	C.TS4_2	C.TS5_2	C.TS6_2	C.TS7_2	C.TS8_2	C.SEGAL1_2
3	C.TS4_3	C.TS5_3	C.TS6_3	C.TS7_3	C.TS8_3	C.SEGAL1_3
4	C.TS4_4	C.TS5_4	C.TS6_4	C.TS7_4	C.TS8_4	C.SEGAL1_4
5	C.TS4_5	C.TS5_5	C.TS6_5	C.TS7_5	C.TS8_5	C.SEGAL1_5
6	C.TS4_6	C.TS5_6	C.TS6_6	C.TS7_6	C.TS8_6	C.SEGAL1_6
7	C.TS4_7	C.TS5_7	C.TS6_7	C.TS7_7	C.TS8_7	C.SEGAL1_7
8	C.TS4_8	C.TS5_8	C.TS6_8	C.TS7_8	C.TS8_8	C.SEGAL1_8
9	C.TS4_9	C.TS5_9	C.TS6_9	C.TS7_9	C.TS8_9	C.SEGAL1_9
10	C.TS4_10	C.TS5_10	C.TS6_10	C.TS7_10	C.TS8_10	C.SEGAL1_10
11	C.TS4_11	C.TS5_11	C.TS6_11	C.TS7_11	C.TS8_11	C.SEGAL1_11
12	C.TS4_12	C.TS5_12	C.TS6_12	C.TS7_12	C.TS8_12	C.SEGAL1_12
13	C.TS4_13	C.TS5_13	C.TS6_13	C.TS7_13	C.TS8_13	C.SEGAL1_13
14	C.TS4_14	C.TS5_14	C.TS6_14	C.TS7_14	C.TS8_14	C.SEGAL1_14
15	C.TS4_15	C.TS5_15	C.TS6_15	C.TS7_15	C.TS8_15	C.SEGAL1_15
16	C.TS4_16	C.TS5_16	C.TS6_16	C.TS7_16	C.TS8_16	C.SEGAL1_16
17	C.TS4_17	C.TS5_17	C.TS6_17	C.TS7_17	C.TS8_17	C.SEGAL1_17
18	C.TS4_18	C.TS5_18	C.TS6_18	C.TS7_18	C.TS8_18	C.SEGAL1_18
19	C.TS4_19	C.TS5_19	C.TS6_19	C.TS7_19	C.TS8_19	C.SEGAL1_19
20	C.TS4_20	C.TS5_20	C.TS6_20	C.TS7_20	C.TS8_20	C.SEGAL1_20
21	C.TS4_21	C.TS5_21	C.TS6_21	C.TS7_21	C.TS8_21	C.SEGAL1_21
22	C.TS4_22	C.TS5_22	C.TS6_22	C.TS7_22	C.TS8_22	C.SEGAL1_22
23	C.TS4_23	C.TS5_23	C.TS6_23	C.TS7_23	C.TS8_23	C.SEGAL1_23
24	C.TS4_24	C.TS5_24	C.TS6_24	C.TS7_24	C.TS8_24	C.SEGAL1_24
25	C.TS4_25	C.TS5_25	C.TS6_25	C.TS7_25	C.TS8_25	C.SEGAL1_25
26	C.TS4_26	C.TS5_26	C.TS6_26	C.TS7_26	C.TS8_26	C.SEGAL1_26
27	C.TS4_27	C.TS5_27	C.TS6_27	C.TS7_27	C.TS8_27	C.SEGAL1_27
28	C.TS4_28	C.TS5_28	C.TS6_28	C.TS7_28	C.TS8_28	C.SEGAL1_28
29	C.TS4_29	C.TS5_29	C.TS6_29	C.TS7_29	C.TS8_29	C.SEGAL1_29
30	C.TS4_30	C.TS5_30	C.TS6_30	C.TS7_30	C.TS8_30	C.SEGAL1_30
31	C.TS4_31	C.TS5_31	C.TS6_31	C.TS7_31	C.TS8_31	C.SEGAL1_31
32	C.TS4_32	C.TS5_32	C.TS6_32	C.TS7_32	C.TS8_32	C.SEGAL1_32
33	C.TS4_33	C.TS5_33	C.TS6_33	C.TS7_33	C.TS8_33	C.SEGAL1_33
34	C.TS4_34	C.TS5_34	C.TS6_34	C.TS7_34	C.TS8_34	C.SEGAL1_34
35	C.TS4_35	C.TS5_35	C.TS6_35	C.TS7_35	C.TS8_35	C.SEGAL1_35
36	C.TS4_36	C.TS5_36	C.TS6_36	C.TS7_36	C.TS8_36	C.SEGAL1_36
37	C.TS4_37	C.TS5_37	C.TS6_37	C.TS7_37	C.TS8_37	C.SEGAL1_37
38	C.TS4_38	C.TS5_38	C.TS6_38	C.TS7_38	C.TS8_38	C.SEGAL1_38
39	C.TS4_39	C.TS5_39	C.TS6_39	C.TS7_39	C.TS8_39	C.SEGAL1_39
40	C.TS4_40	C.TS5_40	C.TS6_40	C.TS7_40	C.TS8_40	C.SEGAL1_40
41	C.TS4_41	C.TS5_41	C.TS6_41	C.TS7_41	C.TS8_41	C.SEGAL1_41
42	C.TS4_42	C.TS5_42	C.TS6_42	C.TS7_42	C.TS8_42	C.SEGAL1_42
43	C.TS4_43	C.TS5_43	C.TS6_43	C.TS7_43	C.TS8_43	C.SEGAL1_43
44	C.TS4_44	C.TS5_44	C.TS6_44	C.TS7_44	C.TS8_44	C.SEGAL1_44
45	C.TS4_45	C.TS5_45	C.TS6_45	C.TS7_45	C.TS8_45	C.SEGAL1_45
46	C.TS4_46	C.TS5_46	C.TS6_46	C.TS7_46	C.TS8_46	C.SEGAL1_46
47	C.TS4_47	C.TS5_47	C.TS6_47	C.TS7_47	C.TS8_47	C.SEGAL1_47
48	C.TS4_48	C.TS5_48	C.TS6_48	C.TS7_48	C.TS8_48	C.SEGAL1_48
49	C.TS4_49	C.TS5_49	C.TS6_49	C.TS7_49	C.TS8_49	C.SEGAL1_49

D-Reg.	FILE8	FILE9	FILE10	FILE11	FILE12	FILE13
	3000	3100	3200	3300	3400	3500
50	C.TS4_50	C.TS5_50	C.TS6_50	C.TS7_50	C.TS8_50	C.SEGAL_1_50
51	C.TS4_51	C.TS5_51	C.TS6_51	C.TS7_51	C.TS8_51	C.SEGAL_1_51
52	C.TS4_52	C.TS5_52	C.TS6_52	C.TS7_52	C.TS8_52	C.SEGAL_1_52
53	C.TS4_53	C.TS5_53	C.TS6_53	C.TS7_53	C.TS8_53	C.SEGAL_1_53
54	C.TS4_54	C.TS5_54	C.TS6_54	C.TS7_54	C.TS8_54	C.SEGAL_1_54
55	C.TS4_55	C.TS5_55	C.TS6_55	C.TS7_55	C.TS8_55	C.SEGAL_1_55
56	C.TS4_56	C.TS5_56	C.TS6_56	C.TS7_56	C.TS8_56	C.SEGAL_1_56
57	C.TS4_57	C.TS5_57	C.TS6_57	C.TS7_57	C.TS8_57	C.SEGAL_1_57
58	C.TS4_58	C.TS5_58	C.TS6_58	C.TS7_58	C.TS8_58	C.SEGAL_1_58
59	C.TS4_59	C.TS5_59	C.TS6_59	C.TS7_59	C.TS8_59	C.SEGAL_1_59
60	C.TS4_60	C.TS5_60	C.TS6_60	C.TS7_60	C.TS8_60	C.SEGAL_1_60
61	C.TS4_61	C.TS5_61	C.TS6_61	C.TS7_61	C.TS8_61	C.SEGAL_1_61
62	C.TS4_62	C.TS5_62	C.TS6_62	C.TS7_62	C.TS8_62	C.SEGAL_1_62
63	C.TS4_63	C.TS5_63	C.TS6_63	C.TS7_63	C.TS8_63	C.SEGAL_1_63
64	C.TS4_64	C.TS5_64	C.TS6_64	C.TS7_64	C.TS8_64	C.SEGAL_1_64
65	C.TS4_65	C.TS5_65	C.TS6_65	C.TS7_65	C.TS8_65	C.SEGAL_1_65
66	C.TS4_66	C.TS5_66	C.TS6_66	C.TS7_66	C.TS8_66	C.SEGAL_1_66
67	C.TS4_67	C.TS5_67	C.TS6_67	C.TS7_67	C.TS8_67	C.SEGAL_1_67
68	C.TS4_68	C.TS5_68	C.TS6_68	C.TS7_68	C.TS8_68	C.SEGAL_1_68
69	C.TS4_69	C.TS5_69	C.TS6_69	C.TS7_69	C.TS8_69	C.SEGAL_1_69
70	C.TS4_70	C.TS5_70	C.TS6_70	C.TS7_70	C.TS8_70	C.SEGAL_1_70
71	C.TS4_71	C.TS5_71	C.TS6_71	C.TS7_71	C.TS8_71	C.SEGAL_1_71
72	C.TS4_72	C.TS5_72	C.TS6_72	C.TS7_72	C.TS8_72	C.SEGAL_1_72
73	C.TS4_73	C.TS5_73	C.TS6_73	C.TS7_73	C.TS8_73	C.SEGAL_1_73
74	C.TS4_74	C.TS5_74	C.TS6_74	C.TS7_74	C.TS8_74	C.SEGAL_1_74
75	C.TS4_75	C.TS5_75	C.TS6_75	C.TS7_75	C.TS8_75	C.SEGAL_1_75
76	C.TS4_76	C.TS5_76	C.TS6_76	C.TS7_76	C.TS8_76	C.SEGAL_1_76
77	C.TS4_77	C.TS5_77	C.TS6_77	C.TS7_77	C.TS8_77	C.SEGAL_1_77
78	C.TS4_78	C.TS5_78	C.TS6_78	C.TS7_78	C.TS8_78	C.SEGAL_1_78
79	C.TS4_79	C.TS5_79	C.TS6_79	C.TS7_79	C.TS8_79	C.SEGAL_1_79
80	C.TS4_80	C.TS5_80	C.TS6_80	C.TS7_80	C.TS8_80	C.SEGAL_1_80
81	C.TS4_81	C.TS5_81	C.TS6_81	C.TS7_81	C.TS8_81	C.SEGAL_1_81
82	C.TS4_82	C.TS5_82	C.TS6_82	C.TS7_82	C.TS8_82	C.SEGAL_1_82
83	C.TS4_83	C.TS5_83	C.TS6_83	C.TS7_83	C.TS8_83	C.SEGAL_1_83
84	C.TS4_84	C.TS5_84	C.TS6_84	C.TS7_84	C.TS8_84	C.SEGAL_1_84
85	C.TS4_85	C.TS5_85	C.TS6_85	C.TS7_85	C.TS8_85	C.SEGAL_1_85
86	C.TS4_86	C.TS5_86	C.TS6_86	C.TS7_86	C.TS8_86	C.SEGAL_1_86
87	C.TS4_87	C.TS5_87	C.TS6_87	C.TS7_87	C.TS8_87	C.SEGAL_1_87
88	C.TS4_88	C.TS5_88	C.TS6_88	C.TS7_88	C.TS8_88	C.SEGAL_1_88
89	C.TS4_89	C.TS5_89	C.TS6_89	C.TS7_89	C.TS8_89	C.SEGAL_1_89
90	C.TS4_90	C.TS5_90	C.TS6_90	C.TS7_90	C.TS8_90	C.SEGAL_1_90
91	C.TS4_91	C.TS5_91	C.TS6_91	C.TS7_91	C.TS8_91	C.SEGAL_1_91
92	C.TS4_92	C.TS5_92	C.TS6_92	C.TS7_92	C.TS8_92	C.SEGAL_1_92
93	C.TS4_93	C.TS5_93	C.TS6_93	C.TS7_93	C.TS8_93	C.SEGAL_1_93
94	C.TS4_94	C.TS5_94	C.TS6_94	C.TS7_94	C.TS8_94	C.SEGAL_1_94
95	C.TS4_95	C.TS5_95	C.TS6_95	C.TS7_95	C.TS8_95	C.SEGAL_1_95
96	C.TS4_96	C.TS5_96	C.TS6_96	C.TS7_96	C.TS8_96	C.SEGAL_1_96
97	C.TS4_97	C.TS5_97	C.TS6_97	C.TS7_97	C.TS8_97	C.SEGAL_1_97
98	C.TS4_98	C.TS5_98	C.TS6_98	C.TS7_98	C.TS8_98	C.SEGAL_1_98
99	C.TS4_99	C.TS5_99	C.TS6_99	C.TS7_99	C.TS8_99	C.SEGAL_1_99

D-Register 3600 ~ 4199

D-Reg.	FILE14	FILE15	FILE16	FILE17	RESERVED	RESERVED
	3600	3700	3800	3900	4000	4100
0						
1	C.SEGAL2_1	C.SEGAL3_1	C.SEGAL4_1	C.SEGPID_1		
2	C.SEGAL2_2	C.SEGAL3_2	C.SEGAL4_2	C.SEGPID_2		
3	C.SEGAL2_3	C.SEGAL3_3	C.SEGAL4_3	C.SEGPID_3		
4	C.SEGAL2_4	C.SEGAL3_4	C.SEGAL4_4	C.SEGPID_4		
5	C.SEGAL2_5	C.SEGAL3_5	C.SEGAL4_5	C.SEGPID_5		
6	C.SEGAL2_6	C.SEGAL3_6	C.SEGAL4_6	C.SEGPID_6		
7	C.SEGAL2_7	C.SEGAL3_7	C.SEGAL4_7	C.SEGPID_7		
8	C.SEGAL2_8	C.SEGAL3_8	C.SEGAL4_8	C.SEGPID_8		
9	C.SEGAL2_9	C.SEGAL3_9	C.SEGAL4_9	C.SEGPID_9		
10	C.SEGAL2_10	C.SEGAL3_10	C.SEGAL4_10	C.SEGPID_10		
11	C.SEGAL2_11	C.SEGAL3_11	C.SEGAL4_11	C.SEGPID_11		
12	C.SEGAL2_12	C.SEGAL3_12	C.SEGAL4_12	C.SEGPID_12		
13	C.SEGAL2_13	C.SEGAL3_13	C.SEGAL4_13	C.SEGPID_13		
14	C.SEGAL2_14	C.SEGAL3_14	C.SEGAL4_14	C.SEGPID_14		
15	C.SEGAL2_15	C.SEGAL3_15	C.SEGAL4_15	C.SEGPID_15		
16	C.SEGAL2_16	C.SEGAL3_16	C.SEGAL4_16	C.SEGPID_16		
17	C.SEGAL2_17	C.SEGAL3_17	C.SEGAL4_17	C.SEGPID_17		
18	C.SEGAL2_18	C.SEGAL3_18	C.SEGAL4_18	C.SEGPID_18		
19	C.SEGAL2_19	C.SEGAL3_19	C.SEGAL4_19	C.SEGPID_19		
20	C.SEGAL2_20	C.SEGAL3_20	C.SEGAL4_20	C.SEGPID_20		
21	C.SEGAL2_21	C.SEGAL3_21	C.SEGAL4_21	C.SEGPID_21		
22	C.SEGAL2_22	C.SEGAL3_22	C.SEGAL4_22	C.SEGPID_22		
23	C.SEGAL2_23	C.SEGAL3_23	C.SEGAL4_23	C.SEGPID_23		
24	C.SEGAL2_24	C.SEGAL3_24	C.SEGAL4_24	C.SEGPID_24		
25	C.SEGAL2_25	C.SEGAL3_25	C.SEGAL4_25	C.SEGPID_25		
26	C.SEGAL2_26	C.SEGAL3_26	C.SEGAL4_26	C.SEGPID_26		
27	C.SEGAL2_27	C.SEGAL3_27	C.SEGAL4_27	C.SEGPID_27		
28	C.SEGAL2_28	C.SEGAL3_28	C.SEGAL4_28	C.SEGPID_28		
29	C.SEGAL2_29	C.SEGAL3_29	C.SEGAL4_29	C.SEGPID_29		
30	C.SEGAL2_30	C.SEGAL3_30	C.SEGAL4_30	C.SEGPID_30		
31	C.SEGAL2_31	C.SEGAL3_31	C.SEGAL4_31	C.SEGPID_31		
32	C.SEGAL2_32	C.SEGAL3_32	C.SEGAL4_32	C.SEGPID_32		
33	C.SEGAL2_33	C.SEGAL3_33	C.SEGAL4_33	C.SEGPID_33		
34	C.SEGAL2_34	C.SEGAL3_34	C.SEGAL4_34	C.SEGPID_34		
35	C.SEGAL2_35	C.SEGAL3_35	C.SEGAL4_35	C.SEGPID_35		
36	C.SEGAL2_36	C.SEGAL3_36	C.SEGAL4_36	C.SEGPID_36		
37	C.SEGAL2_37	C.SEGAL3_37	C.SEGAL4_37	C.SEGPID_37		
38	C.SEGAL2_38	C.SEGAL3_38	C.SEGAL4_38	C.SEGPID_38		
39	C.SEGAL2_39	C.SEGAL3_39	C.SEGAL4_39	C.SEGPID_39		
40	C.SEGAL2_40	C.SEGAL3_40	C.SEGAL4_40	C.SEGPID_40		
41	C.SEGAL2_41	C.SEGAL3_41	C.SEGAL4_41	C.SEGPID_41		
42	C.SEGAL2_42	C.SEGAL3_42	C.SEGAL4_42	C.SEGPID_42		
43	C.SEGAL2_43	C.SEGAL3_43	C.SEGAL4_43	C.SEGPID_43		
44	C.SEGAL2_44	C.SEGAL3_44	C.SEGAL4_44	C.SEGPID_44		
45	C.SEGAL2_45	C.SEGAL3_45	C.SEGAL4_45	C.SEGPID_45		
46	C.SEGAL2_46	C.SEGAL3_46	C.SEGAL4_46	C.SEGPID_46		
47	C.SEGAL2_47	C.SEGAL3_47	C.SEGAL4_47	C.SEGPID_47		
48	C.SEGAL2_48	C.SEGAL3_48	C.SEGAL4_48	C.SEGPID_48		
49	C.SEGAL2_49	C.SEGAL3_49	C.SEGAL4_49	C.SEGPID_49		

D-Reg.	FILE14	FILE15	FILE16	FILE17	RESERVED	RESERVED
	3600	3700	3800	3900	4000	4100
50	C.SEGAL2_50	C.SEGAL3_50	C.SEGAL4_50	C.SEGPID_50		
51	C.SEGAL2_51	C.SEGAL3_51	C.SEGAL4_51	C.SEGPID_51		
52	C.SEGAL2_52	C.SEGAL3_52	C.SEGAL4_52	C.SEGPID_52		
53	C.SEGAL2_53	C.SEGAL3_53	C.SEGAL4_53	C.SEGPID_53		
54	C.SEGAL2_54	C.SEGAL3_54	C.SEGAL4_54	C.SEGPID_54		
55	C.SEGAL2_55	C.SEGAL3_55	C.SEGAL4_55	C.SEGPID_55		
56	C.SEGAL2_56	C.SEGAL3_56	C.SEGAL4_56	C.SEGPID_56		
57	C.SEGAL2_57	C.SEGAL3_57	C.SEGAL4_57	C.SEGPID_57		
58	C.SEGAL2_58	C.SEGAL3_58	C.SEGAL4_58	C.SEGPID_58		
59	C.SEGAL2_59	C.SEGAL3_59	C.SEGAL4_59	C.SEGPID_59		
60	C.SEGAL2_60	C.SEGAL3_60	C.SEGAL4_60	C.SEGPID_60		
61	C.SEGAL2_61	C.SEGAL3_61	C.SEGAL4_61	C.SEGPID_61		
62	C.SEGAL2_62	C.SEGAL3_62	C.SEGAL4_62	C.SEGPID_62		
63	C.SEGAL2_63	C.SEGAL3_63	C.SEGAL4_63	C.SEGPID_63		
64	C.SEGAL2_64	C.SEGAL3_64	C.SEGAL4_64	C.SEGPID_64		
65	C.SEGAL2_65	C.SEGAL3_65	C.SEGAL4_65	C.SEGPID_65		
66	C.SEGAL2_66	C.SEGAL3_66	C.SEGAL4_66	C.SEGPID_66		
67	C.SEGAL2_67	C.SEGAL3_67	C.SEGAL4_67	C.SEGPID_67		
68	C.SEGAL2_68	C.SEGAL3_68	C.SEGAL4_68	C.SEGPID_68		
69	C.SEGAL2_69	C.SEGAL3_69	C.SEGAL4_69	C.SEGPID_69		
70	C.SEGAL2_70	C.SEGAL3_70	C.SEGAL4_70	C.SEGPID_70		
71	C.SEGAL2_71	C.SEGAL3_71	C.SEGAL4_71	C.SEGPID_71		
72	C.SEGAL2_72	C.SEGAL3_72	C.SEGAL4_72	C.SEGPID_72		
73	C.SEGAL2_73	C.SEGAL3_73	C.SEGAL4_73	C.SEGPID_73		
74	C.SEGAL2_74	C.SEGAL3_74	C.SEGAL4_74	C.SEGPID_74		
75	C.SEGAL2_75	C.SEGAL3_75	C.SEGAL4_75	C.SEGPID_75		
76	C.SEGAL2_76	C.SEGAL3_76	C.SEGAL4_76	C.SEGPID_76		
77	C.SEGAL2_77	C.SEGAL3_77	C.SEGAL4_77	C.SEGPID_77		
78	C.SEGAL2_78	C.SEGAL3_78	C.SEGAL4_78	C.SEGPID_78		
79	C.SEGAL2_79	C.SEGAL3_79	C.SEGAL4_79	C.SEGPID_79		
80	C.SEGAL2_80	C.SEGAL3_80	C.SEGAL4_80	C.SEGPID_80		
81	C.SEGAL2_81	C.SEGAL3_81	C.SEGAL4_81	C.SEGPID_81		
82	C.SEGAL2_82	C.SEGAL3_82	C.SEGAL4_82	C.SEGPID_82		
83	C.SEGAL2_83	C.SEGAL3_83	C.SEGAL4_83	C.SEGPID_83		
84	C.SEGAL2_84	C.SEGAL3_84	C.SEGAL4_84	C.SEGPID_84		
85	C.SEGAL2_85	C.SEGAL3_85	C.SEGAL4_85	C.SEGPID_85		
86	C.SEGAL2_86	C.SEGAL3_86	C.SEGAL4_86	C.SEGPID_86		
87	C.SEGAL2_87	C.SEGAL3_87	C.SEGAL4_87	C.SEGPID_87		
88	C.SEGAL2_88	C.SEGAL3_88	C.SEGAL4_88	C.SEGPID_88		
89	C.SEGAL2_89	C.SEGAL3_89	C.SEGAL4_89	C.SEGPID_89		
90	C.SEGAL2_90	C.SEGAL3_90	C.SEGAL4_90	C.SEGPID_90		
91	C.SEGAL2_91	C.SEGAL3_91	C.SEGAL4_91	C.SEGPID_91		
92	C.SEGAL2_92	C.SEGAL3_92	C.SEGAL4_92	C.SEGPID_92		
93	C.SEGAL2_93	C.SEGAL3_93	C.SEGAL4_93	C.SEGPID_93		
94	C.SEGAL2_94	C.SEGAL3_94	C.SEGAL4_94	C.SEGPID_94		
95	C.SEGAL2_95	C.SEGAL3_95	C.SEGAL4_95	C.SEGPID_95		
96	C.SEGAL2_96	C.SEGAL3_96	C.SEGAL4_96	C.SEGPID_96		
97	C.SEGAL2_97	C.SEGAL3_97	C.SEGAL4_97	C.SEGPID_97		
98	C.SEGAL2_98	C.SEGAL3_98	C.SEGAL4_98	C.SEGPID_98		
99	C.SEGAL2_99	C.SEGAL3_99	C.SEGAL4_99	C.SEGPID_99		



SAMWONTECH CO., LTD.

202-703, Buchon Techno-Park,
Yakdae-dong, Wonmi-gu, Buchon-si
Gyeonggi-do, Korea 420-773
TEL : +82-32-326-9120
FAX : +82-32-326-9119
Website: <http://www.samwontech.com>
e-mail : webmater@samwontech.com

Further information contact SAMWONTECH