

TEMP1000 SERIES



COMMUNICATION MANUAL

※ This manual applies to TEMP1300, TEMP1500 and TEMP1900
The model stated the manual content is TEMP1500.

Contents

1. Safety Precautions	1
2. Communication Specifications	3
3. Communication Setting	4
4. Wiring for Communication	5
5. Communication Command	7
6. MODBUS Protocol	18
7. D-REGISTER Description	24
▪ D-REGISTER table	50

1. Safety Precautions

Thank you for purchasing TEMP1500, programmable controller.
This Communication Manual describes communication of the TEMP1500 controller.



SAFETY SYMBOL MARK

(A) Symbolizes 'Caution' and 'Warning'. The information with this symbol is especially important for preventing from user injury and protecting the product and system.



(1)Product : This symbol indicates an imminently hazardous situation which if not avoided, will result in serious injury or system damage.

(2)Communication Manual : This symbol indicates potential hazard that may cause personal injury by electrical shock.

(B) Symbolizes 'Protective Earth (PE) Terminal.'



This symbol indicates that the terminal must be connected to the Ground prior to operating.

(C) Symbolizes 'Supplementary Explanation.'



The information with this symbol describes additional explanation for features.

(D) Symbolizes 'Reference.'



This symbol indicates further information and page to refer.



Precautionary Remarks on this Communication Manual

- (A) This manual should be passed on the End- User and kept at a suitable place for easy review in time.
- (B) Read and understand this Communication Manual carefully before using the product.
- (C) This Communication Manual describes functions and features of the product in detail, and SAMWONTECH can not guarantee against over applications would suit a customer's particular purpose which is not described in this manual.
- (D) Unauthorized duplication and modification of this Communication Manual are strongly prohibited.
- (E) The contents of this manual may be modified without prior notice.
- (F) If any errors or omissions in this manual should come to the attention of the user, feel free to contact our sales representatives or our sales office.



Precautions for Safety and Unauthorized Modification

- (A) For protecting and ensuring the safety of this product and relevant system, all of the safety instructions and precautions should be well recognized and strictly observed by all users.
- (B) SAMWONTECH does not guarantee against damage resulting from unauthorized alteration, misuse, or abuse.
- (C) When using additional safety circuit or part such as Noise Filter to protect this product and relevant system, it is strongly required to install that to outside of this product. Additional installation and modification inside of this product are prohibited.
- (D) Do not try to disassemble, repair, or modify the product. It may become the cause of a trouble such as malfunction, electric shock, fire.
- (E) Contact our sales dept. for part replacement or consumables.
- (F) Keep the product away from water inflowing. This may become a critical cause of trouble.
- (G) External shock on the product may lead to damage and malfunction.



Limitation of Liability

- (A) SAMWONTECH does not guarantee or accept responsibility for this product other than the clauses stated in our warranty policy.
- (B) SAMWONTECH assumes no liability to any party for any loss or damage, direct or indirect, caused by the use or any unpredictable defect of the product.



Warranty Policy

- (A) Warranty term of this TEMP1500 is one year after delivery to the first purchaser for being free of defects in materials and faulty workmanship under the condition that the product has been applied according to this manual.
- (B) The repairing cost will be charged for defective product out of warranty period. This charge will be the actual cost estimated by SAMWONTECH.
- (C) Repairing cost may be charged even if within warranty period for following cases.
 - (1) Damage due to USER FAULT (Ex.: Product initialization by password loss).
 - (2) Damage due to natural disaster (Ex.: fire, flood).
 - (3) Damage due to additional removal and re-installation after the first one.
 - (4) Damage due to unauthorized disassembles, modification and alternation.
 - (5) Damage due to unexpected power failure caused unstable power supply.
 - (6) Others
- (D) If any A/S is required, feel free to contact our sales office or a representative.

2. Communication Specification

The TEMP1500 controller provides Half-Duplex method support on RS232C and RS485 communication interface.

- RS232C interface supports 1:1 direct communication between host computer on network system and TEMP1500.
- RS485 interface supports to connect upper level network system with up to 31 slave TEMP1500 controller.

■ Parameters for communication setting

Parameter	Range	Description
PROTOCOL	PCLINK	Default protocol
	PCLINK+SUM	Default protocol + CheckSum
	MODBUS ASC	MODBUS ASCII
	MODBUS RTU	MODBUS RTU
SPEED (BPS)	9600	9600 bps
	19200	19200 bps
	38400	38400 bps
	57600	57600 bps
	115200	115200 bps
PARITY	NONE	None Parity
	EVEN	Even Parity
	ODD	Odd Parity
STOP BIT	1	1 bit
	2	2 bits
DATA LENGTH	7	7 bits
	8	8 bits
ADDRESS	1~99	Address
RESPONSE TIME	0~10	RESPONSE TIME(=PROCESS TIME+SPONSE TIME*10msec)
SYNC MASTER	OFF	OFF
	ON	ON

■ Factory default value

• PROTOCOL	PCLINK+SUM(PCLINK+CheckSum)
• BPS	9600 bps
• PARITY	NONE
• STOP BIT	1 (1 bit)
• DATA LENGTH	8 (8 bits)
• ADDRESS	1
• RESPONSE TIME	0 (PROCESS TIME+10msec)
• SYNC MASTER	OFF

3. Communication setting

TEMP1500 provides flexible communication interface RS232C or RS485 from Control Unit directly.

- ▶ In [Figure 1], Using a flat-blade screwdriver to remove the cover.
 - ▶ In [Figure 2], Communication settings by moving the socket
 - ▶ It is recommended to use tool like tweezers for setting socket to pin-header correctly.
- 👁 **Make sure setup completed correctly.**

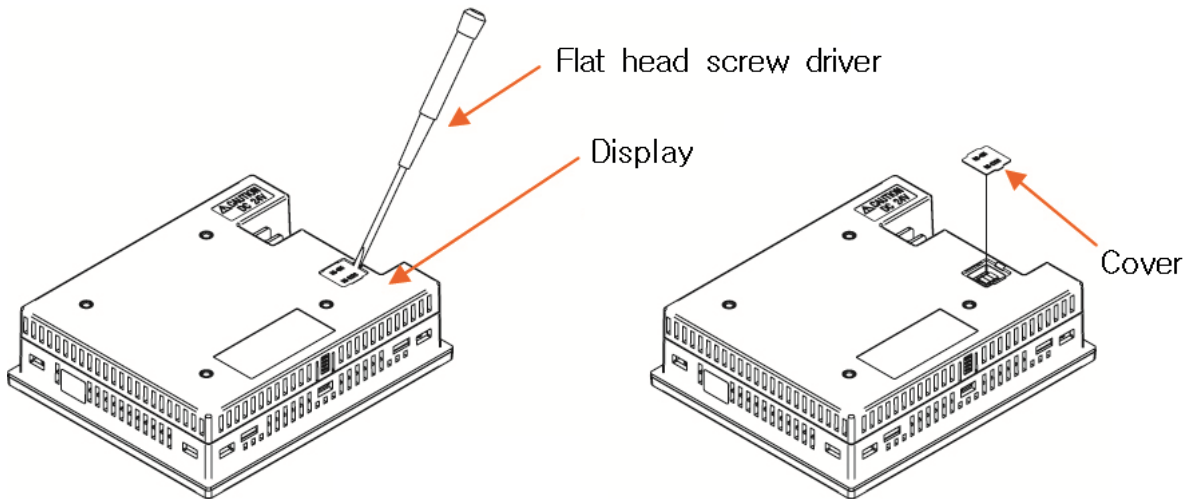

[Figure-1] TEMP1500 Display

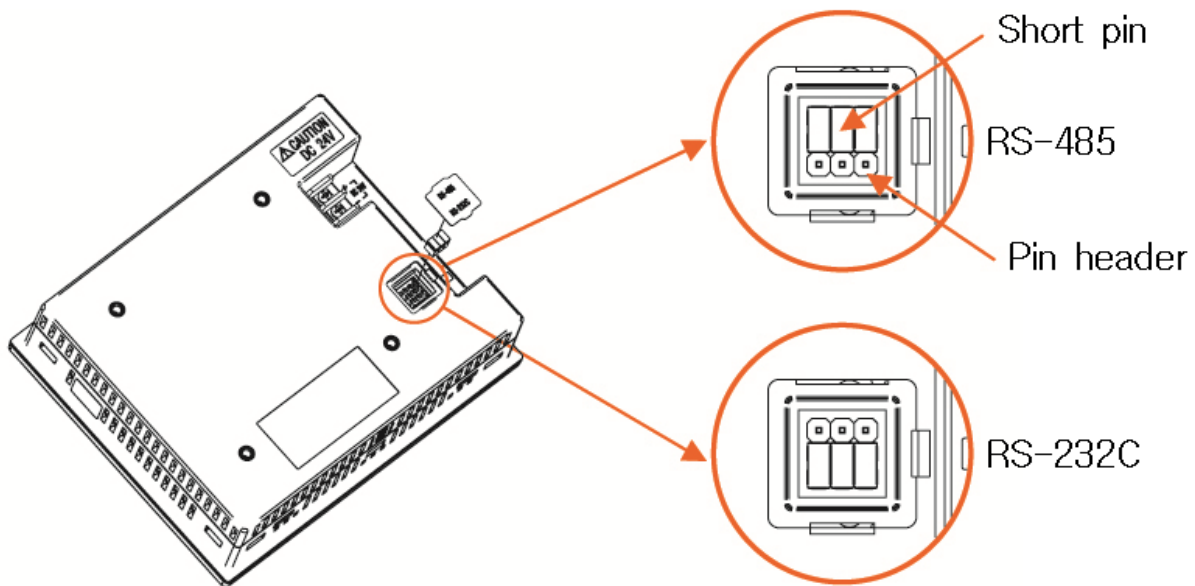

[Figure-2] TEMP1500 Communication Setting



- ▶ Do not disassemble Power board from Control Unit case during setting comm. interface.
- ▶ It is recommended to use tool like tweezers for setting comm. interface.
- ▶ Make sure setup completed correctly.

4. Wiring for Communication

Connector wiring between TEMP1500 and network system depends on communication interface setting (RS232C/RS485).

■ Modular Connector Pin-Mapping for COM2 port

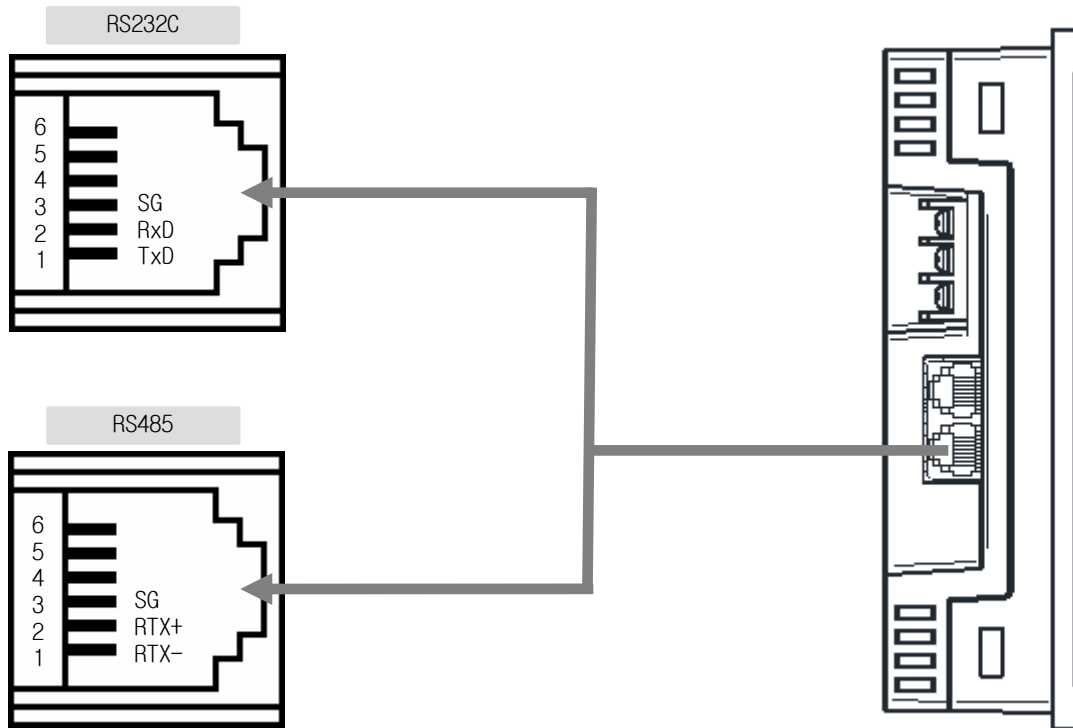

■ Description of Modular Connector Pin-Mapping for COM2 port

PIN no.	RS232C		RS485	
	Signal	Symbol	Signal	Symbol
1	Transmit Data	TxD	Receive/Transmit Data -	RTX-
2	Receive Data	RxD	Receive/Transmit Data +	RTX+
3	Signal Ground	SG	Signal Ground	SG
4	-	-	-	-
5	-	-	-	-
6	-	-	-	-

6 Pin connector wiring for RS232C interface

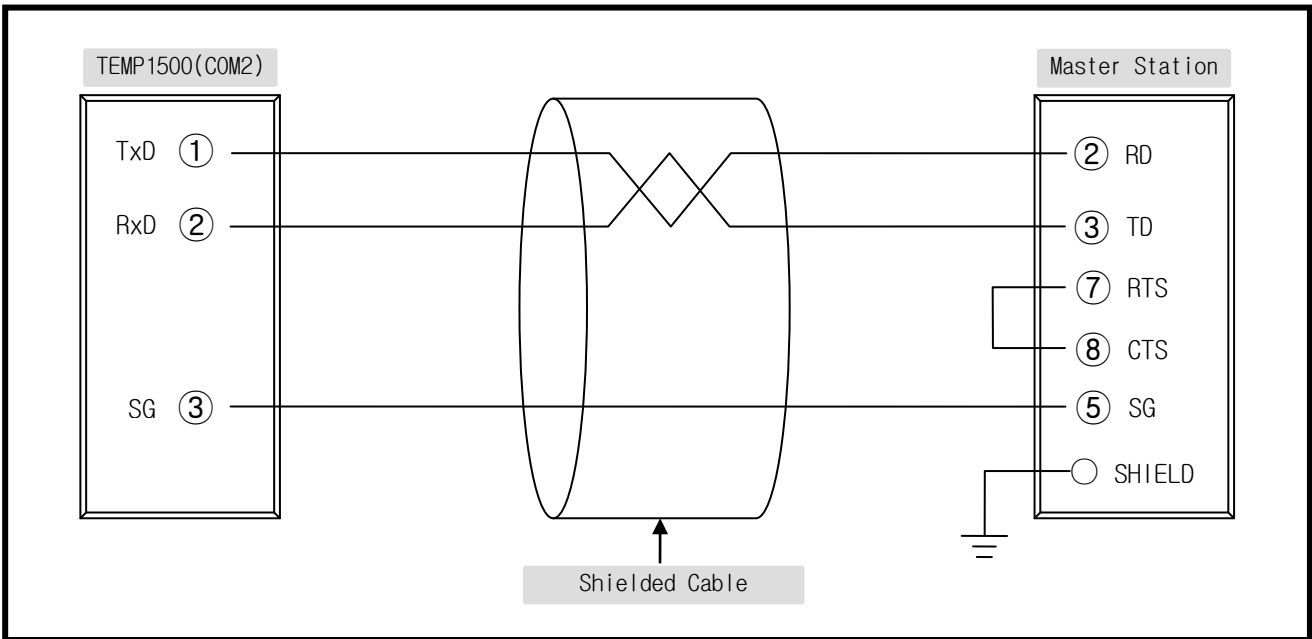

6 Pin connector wiring for RS485 interface

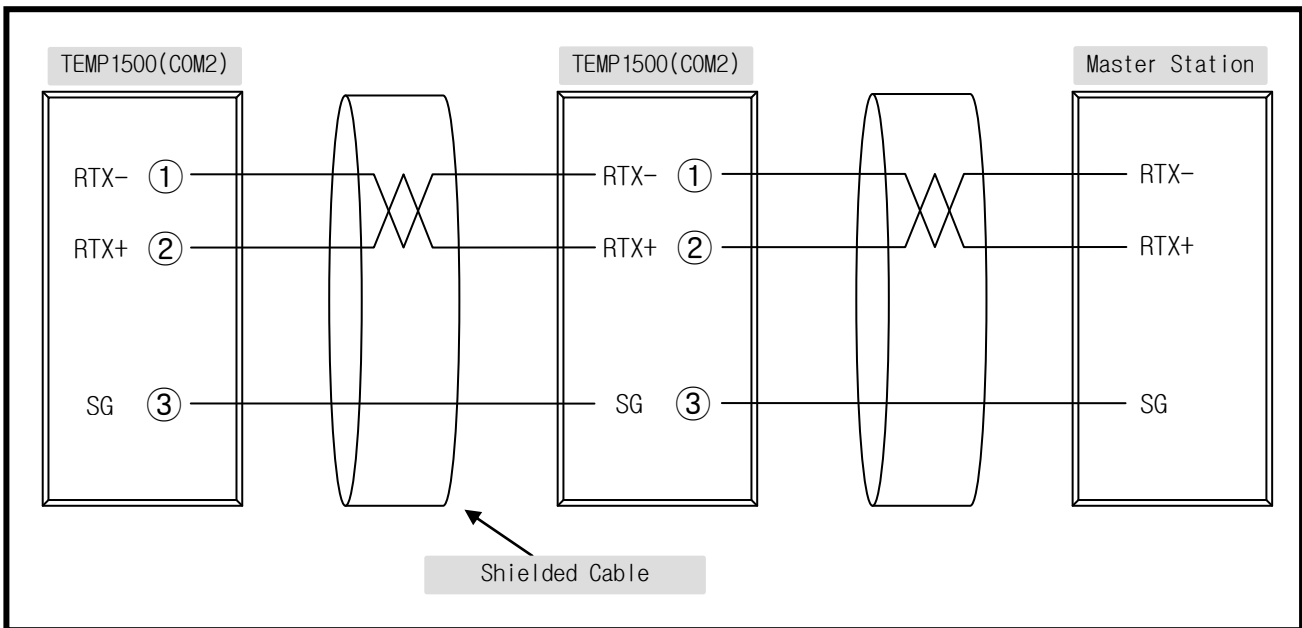

Up to 31 slave TEMP1500 controllers can be connected to a master device by multi-drop networking.

Make sure to install 200Ω (1/4W) resistor on Last Leg at both end of terminal Slave and Master(PC, PLC).

5. Communication Command

5.1 The Frame Structure of standard protocol

The frame structure of protocol transmitting upper-level network system to TEMP1500

①	②	③	④	⑤	⑥	⑦	⑧
STX	Address	Command	,	Data	SUM	CR	LF

① Protocol Header

The beginning of communication command with STX (Start of Text), ASCII string with 0x02.

② Slave TEMP1500 Address

Slave unit address of TEMP1500.

③ Command

Function Command for communication. (Refer to 5.2 ~ 5.10).

④ Delimiter

Symbolize to separate Command and Data by Comma. (',')

⑤ Data

Formal text strings regulated by communication command rule.

⑥ Check Sum

- 'SUM' protocol is a more sophisticated one which includes Check Sum as an error check.
- Check Sum is calculated as following.

- 1) Add the ASCII code of characters from the character next to STX one by one up to the character prior to SUM
- 2) Represent the lowest one byte of the sum as a hexadecimal notation (2 characters).

⑦, ⑧ Protocol Tail

ASCII code to close communication command by indicating CR(0x0D) and LF(0x0A).

■ Example for SUM

◆ Example

To read the consecutively D-Register from D0001 (NPV) to D0005 (MVOUT)

- Rrequest : [stx]01RSD,05,0001[cr][lf]
- Rrequest (with CheckSum) : [stx]01RSD,05,0001**C8**[cr][lf]

☞ As shown below, hexa decimal value adding each text at 01RSD,05,0001 by ASCII code is 2C8, and lower digit 2 characters **C8** will be used for CheckSum.

Text	0	1	R	S	D	,	0	5	,	0	0	0	1
Ascii value	30	31	52	53	44	2C	30	35	2C	30	30	30	31



■ ASCII Table

High Low	0	1	2	3	4	5	6	7
0	NUL	DLE	SPACE	0	@	P	`	p
1	SOH	DC1	!	1	A	Q	a	q
2	STX	DC2	"	2	B	R	b	r
3	ETX	DC3	#	3	C	S	c	s
4	EOT	DC4	\$	4	D	T	d	t
5	ENQ	NAK	%	5	E	U	e	u
6	ACK	SYN	&	6	F	V	f	v
7	BEL	ETB	'	7	G	W	g	w
8	BS	CAN	(8	H	X	h	x
9	HT	EM)	9	I	Y	i	y
A	LF	SUB	*	:	J	Z	j	z
B	VT	ESC	+	;	K	[k	{
C	FF	FS	,	<	L	¥	l	
D	CR	GS	-	=	M]	m	}
E	SO	RS	.	>	N	^	n	~
F	SI	US	/	?	O	_	o	DEL

5.2 Type of Communication Command

Two types of commands are provided on TEMP1500. One is general READ/WRITE command to read and write information on D-Register, and the other is Reference command to read self-information of TEMP1500.

■ Reference Command

Command	Description
AMI	Displays model name and Version-Revision of TEMP1500

■ Read/Write Command

Command	Description
RSD	Read data in consecutive D-Register in sequence (Read)
RRD	Read data in arbitrary single D-Register (Read)
WSD	Write data in consecutive D-Register in sequence (Write)
WRD	Write data in arbitrary single D-Register (Write)
STD	Register arbitrary single address to monitor (D-Register Monitoring Set)
CLD	Read data in address registered by STD command (D-Register Monitoring Call)

☞ Each Command can read or write up to 64 D-Register and all of the SED/CLD data will be reset by power OFF, so the data should be registered again.

5.3 ERROR Response

When an Error occurs during communication, TEMP1500 transmits a frame as following.

bytes	1	2	2	2	2	1	1
Frame	STX	Address	NG	Error Code	SUM	CR	LF

▣ Description of Error Code

Error Code	Description	Remarks
01	Invalid Command setting	
02	Invalid D-Register setting	
04	Data Setting Error	Invalid text data input (Available 0~9, A~F : hexadecimals)
08	Invalid Format configuration	<ul style="list-style-type: none"> ▪ Different command format with designated ▪ Differnet number of setting with designated
11	Checksum Error	
12	Monitoring Command Error	No setup Monitoring Command
00	Other Errors	

5.4 RSD Command

RSD Command is used to read data in a part of D-Register by consecutive address in sequence.

Request Message Frame

bytes	1	2	3	1	2	1	4	2	1	1
Frame	STX	Address	RSD	,	Count Number	,	D-Reg.	SUM	CR	LF

Response Message Frame

bytes	1	2	3	1	2	1	4	1	...
Frame	STX	Address	RSD	,	OK	,	Data - 1	,	...

1	4	2	1	1
,	Data - n	SUM	CR	LF

- Count Number : 1 ~ 64
- Data : Hexa-decimal 16bit string 4 character with no decimal point

Example

To read the D-Register **FROM** D0001 (NPV) **TO** D0002 (NSP)

- Request : [stx]01RSD,03,0001[cr][lf]
- Request (with CheckSum) : [stx]01RSD,03,0001C6[cr][lf]
([stx] = 0x02, [cr] = 0x0d, [lf] = 0x0a)

Response data will be same as below, when 50.0 of D0001 (NPV) and 30.0 of D0002 (NSP)

- Response : [stx]01RSD,OK,01F4,0000,012C[cr][lf]
- Response (with CheckSum) : [stx]01RSD,OK,01F4,0000,012C19[cr][lf]

※ Converting procedure 4digits hexadecimal response to decimal value.

- ① Radix conversion (Decimalize) : 01F4(hexadecimal) → 500(decimal)
- ② Multiply factor (decimal point) : 500 * 0.1 → 50.0

5.5 RRD Command

RRD Command is used to read data in arbitrary single D-Register.

Request Message Frame

bytes	1	2	3	1	2	1	4	1	...
Frame	STX	Address	RRD	,	Count Number	,	D-Reg.- 1	,	...

1	4	2	1	1
,	D-Reg.- n	SUM	CR	LF

Response Message Frame

bytes	1	2	3	1	2	1	4	1	...
Frame	STX	Address	RRD	,	OK	,	Data - 1	,	...

1	4	2	1	1
,	Data - n	SUM	CR	LF

- Count Number : 1 ~ 64
- Data : Hexa-decimal 16bit string 4 character with no decimal point

Example

To read the D-Register D0001 (NPV) and D0002 (NSP)

- Request : [stx]01RRD,02,0001,0002[cr][lf]
- Request (with CheckSum) : [stx]01RRD,02,0001,0002B2[cr][lf]

Response data will be same as below, when 50.0 of D0001 (NPV) and 30.0 of D0002 (NSP)

- Response : [stx]01RRD,OK,01F4,012C[cr][lf]
- Response (with CheckSum) : [stx]01RRD,OK,01F4,012C18[cr][lf]

5.6 WSD Command

WSD command is used to write data to a part of D-Register by consecutive address in sequence.

Request Message Frame

bytes	1	2	3	1	2	1	4	1	4
Frame	STX	Address	WSD	,	Count Number	,	D-Reg.	,	Data - 1

1	...	1	4	2	1	1
,	...	,	Data - n	SUM	CR	LF

Response Message Frame

bytes	1	2	3	1	2	2	1	1
Frame	STX	Address	WSD	,	OK	SUM	CR	LF

- Count Number : 1 ~ 64
- Data : Hexa-decimal 16bit string 4 character with no decimal point

Example

To write data to the D-Register **FROM** D0110 (TEMI.OP_H) **TO** D0111 (TEMI.OP_M) on FIX mode operation

- Setting TIME.OP_H : 99Hour → Hexadecimalize (0x0063)
- Setting TIME.OP_M : 50Min → Hexadecimalize (0x0032)
- Request : [stx]01WSD,02,0110,0063,0032[cr][lf]
- Request(with CheckSum) : [stx]01WSD,02,0110,0063,0032B1[cr][lf]

5.7 WRD Command

WRD Command is used to write data in arbitrary single D-Register.

Request Message Frame

bytes	1	2	3	1	2	1	4	1	4
Frame	STX	Address	WRD	,	Count Number	,	D-Reg.- 1	,	Data - 1

1	...	1	4	1	4	2	1	1
,	...	,	D-Reg. - n	,	Data - n	SUM	CR	LF

Response Message Frame

bytes	1	2	3	1	2	2	1	1
Frame	STX	Address	WRD	,	OK	SUM	CR	LF

- Count Number : 1 ~ 64
- Data : Hexa-decimal 16bit string 4 character with no decimal point

◆ Example

To write 50.0 °C into the D0102(TSP) and 0.5 °C into the D0106(SLOPE) on FIX mode operation.

- Setting TSP : 50.0 °C → Remove decimal point (500) → Hexadecimalize (0x01F4)
- Setting SLOPE : 0.5 °C → Remove decimal point (5) → Hexadecimalize (0x0005)
- Request : [stx]01WRD,02,0102,01F4,0106,0005[cr][lf]
- Request (with CheckSum) : [stx]01WRD,02,0102,01F4,0106,0005B3[cr][lf]

5.8 STD Command

STD Command is used to list the D-Registers that is necessary to monitor frequently.

Request Message Frame

bytes	1	2	3	1	2	1	4	1	4
Frame	STX	Address	STD	,	Count Number	,	D-Reg. - 1	,	D-Reg. - 2

1	...	1	4	1	4	2	1	1
,	...	,	D-Reg. - (n-1)	,	D-Reg. - n	SUM	CR	LF

Response Message Frame

bytes	1	2	3	1	2	2	1	1
Frame	STX	Address	STD	,	OK	SUM	CR	LF

- Count Number : 1 ~ 64

Example

To register D0001 (NPV), D0002 (NSP) and D0007 (MVOUT)

- Request : [stx]01STD,03,0001,0002,0007 [cr][lf]
- Request (with CheckSum) : [stx]01STD,03,0001,0002,0007A9[cr][lf]

5.9 CLD Command

CLD Command is used to read data in the address which had been registered by STD command.

Request Message Frame

bytes	1	2	3	2	1	1
Frame	STX	Address	CLD	SUM	CR	LF

Response Message Frame

byte 수	1	2	3	1	2	1	4	1	4
Frame	STX	Address	CLD	,	OK	,	Data - 1	,	Data - 2

1	...	1	4	1	4	2	1	1
,	...	,	Data - (n-1)	,	Data - n	SUM	CR	LF

- Count Number : 1 ~ 64

Example

- Request : [stx]01CLD[cr][lf]
- Request (with CheckSum) : [stx]01CLD34[cr][lf]

5.10 AMI Command

AMI Command is used to get the controller own-information.

Request Message Frame

bytes	1	2	3	2	1	1
Frame	STX	Address	AMI	SUM	CR	LF

Response Message Frame

bytes	1	2	3	1	2	1
Frame	STX	Address	AMI	,	OK	,

9	2	7	2	1	1
Model Name	SPACE	Version-Revision	SUM	CR	LF

Example

To confirm controller own information

- Request : [stx]01AMI[CR][LF]
- Request (with CheckSum) : [stx]01AMI38[CR][LF]
- Response : [stx]01AMI,OK,TEMP1500[sp][sp][sp]V00[sp]R00[sp][cr][lf]
- Response (with CheckSum) : [stx]01AMI,OK,TEMP1500[sp][sp][sp]V00[sp]R00[sp]06[cr][lf]

6. MODBUS Protocol

6.1 The Frame Structure of MODBUS protocol

▣ Data Format

Item	ASCII	RTU
Protocol Header	:(Colon)	N/A
Protocol Tail	[CR][LF]	N/A
Data length	7-bit(Fixed)	8-bit(Fixed)
Data type	ASCII	Binary
Error detecting	LRC (Longitudinal Redundancy Check)	CRC-16 (Cyclic Redundancy Check)
Data time interval	Under 1sec.	Under 24-bit time

▣ The Frame Structure of MODBUS protocol

▶ Modbus ASCII

Protocol Header	Address	Function Code	Data	LRC Check	Protocol Tail
1 character	2 character	2 character	N character	2 character	2 character (CR+LF)

▶ Modbus RTU

Protocol Header	Address	Function Code	Data	LRC Check	Protocol Tail
N/A	8-Bit	8-Bit	N * 8-Bit	16-Bit	N/A

- N : Number of Hexadecimal data

6.2 Function Code

TEMP1500 MODBUS protocol provides two function code subsets for READ/WRITE of D-Register and Loop-Back detecting test.

Function Code	Description
03	Read data in consecutive D-Register in sequence
06	Write data to arbitrary single D-Register
08	Diagnostics(Loop-Back Test)
16	Write data to consecutive D-Register in sequence



When using MODBUS, D-Register has to be subtracted '1' from the D-Register table we offer this manual, because it starts '0' D-Register address on MODBUS protocol.

6.3 Function code – 03

Function code-03 is used to read the data of consecutive D-Register block in sequence up to 64 registers.

Request Message Frame

Factor	ASCII	RTU
Protocol Header	:(Colon)	-
Slave Address	2 characters	8-Bit
Function code-03	2 characters	8-Bit
D-Register Hi	2 characters	8-Bit
D-Register Lo	2 characters	8-Bit
Address Count Hi	2 characters	8-Bit
Address Count Lo	2 characters	8-Bit
Error detecting	2 characters	16-Bit
Protocol Tail	2 characters (CR+LF)	-

Exmample

Request message to read the D-Register **FROM** D0001 (NPV) **TO** D0002 (NSP) should be

- MODBUS ASCII :010300000002FA[cr][lf]
- MODBUS RTU 010300000002C40B

☞ D-Register has to be subtracted '1' from the designated address number on D-Register table in this manual.

Response Message Frame

Factor	ASCII	RTU
Protocol Header	:(Colon)	-
Slave Address	2 characters	8-Bit
Function code-03	2 characters	8-Bit
Data byte count	2 characters	8-Bit
Data - 1 Hi	2 characters	8-Bit
Data - 1 Lo	2 characters	8-Bit
...
Data - n Hi	2 characters	8-Bit
Data - n Lo	2 characters	8-Bit
Error detecting	2 characters	16-Bit
Protocol Tail	2 characters (CR+LF)	-

Exmample

Response data will be same as below, when 25.0 of D0001 (NPV) and 100.0 of D0002 (NSP)

- MODBUS ASCII :01030400FA03E813[cr][lf]
- MODBUS RTU 01030400FA03E8DABC

6.4 Function code – 06

Function code-06 is used to write data in arbitrary single D-Register.

Request Message Frame

Factor	ASCII	RTU
Protocol Header	:(Colon)	-
Slave Address	2 characters	8-Bit
Function code-06	2 characters	8-Bit
D-Register Hi	2 characters	8-Bit
D-Register Lo	2 characters	8-Bit
Write Data Hi	2 characters	8-Bit
Write Data Lo	2 characters	8-Bit
Error detecting	2 characters	16-Bit
Protocol Tail	2 characters (CR+LF)	-

◆ Example

Request message to write '2' to D0100 (pattern number) should be

- MODBUS ASCII :01060063000294[cr][lf]
- MODBUS RTU 010600630002F815

☞ D-Register has to be subtracted '1' from the designated address number on D-Register table in this manual.

Response Message Frame

Factor	ASCII	RTU
Protocol Header	:(Colon)	-
Slave Address	2 characters	8-Bit
Function code-06	2 characters	8-Bit
D-Register Hi	2 characters	8-Bit
D-Register Lo	2 characters	8-Bit
Write Data Hi	2 characters	8-Bit
Write Data Lo	2 characters	8-Bit
Error detecting	2 characters	16-Bit
Protocol Tail	2 characters (CR+LF)	-

◆ Example

Without any trouble, response message will be.

- MODBUS ASCII :01060063000294[cr][lf]
- MODBUS RTU 010600630002F815

6.5 Function code – 08

Function code-08 is used to test loopback for self-diagnosis.

Request Message Frame

Factor	ASCII	RTU
Protocol Header	:(Colon)	-
Slave Address	2 characters	8-Bit
Function code-08	2 characters	8-Bit
Diagnosis code Hi	2 characters	8-Bit
Diagnosis code Lo	2 characters	8-Bit
Data Hi	2 characters	8-Bit
Data Lo	2 characters	8-Bit
Error detecting	2 characters	16-Bit
Protocol Tail	2 characters (CR+LF)	-

◆ Example

Request message to test loopback for self-diagnosis should be

- MODBUS ASCII :010800000002F5[cr][lf]
- MODBUS RTU 01080000000261CA

Response Message Frame

Factor	ASCII	RTU
Protocol Header	:(Colon)	-
Slave Address	2 characters	8-Bit
Function code-08	2 characters	8-Bit
Diagnosis code Hi	2 characters	8-Bit
Diagnosis code Lo	2 characters	8-Bit
Data Hi	2 characters	8-Bit
Data Lo	2 characters	8-Bit
Error detecting	2 characters	16-Bit
Protocol Tail	2 characters (CR+LF)	-

◆ Example

Without any trouble, response message will be.

- MODBUS ASCII :010800000002F5[cr][lf]
- MODBUS RTU 01080000000261CA

6.6 Function code – 16

Function code-16 is used to write the data into consecutive D-Register block in sequence up to 64 registers.

Request Message Frame

Factor	ASCII	RTU
Protocol Header	:(Colon)	-
Slave address	2 characters	8-Bit
Function code-16	2 characters	8-Bit
D-Register Hi	2 characters	8-Bit
D-Register Lo	2 characters	8-Bit
Address Count Hi	2 characters	8-Bit
Address Count Lo	2 characters	8-Bit
Data byte Count	2 characters	8-Bit
Data – 1 Hi	2 characters	8-Bit
Data – 1 Lo	2 characters	8-Bit
...
Data – n Hi	2 characters	8-Bit
Data – n Lo	2 characters	8-Bit
Error detecting	2 characters	-
Protocol Tail	2 characters (CR+LF)	16-Bit

Example

Request message to write '99' to the D0110(TEMI.OP_H) and '50' to the D0111(TEMI.OP_M) on FIX mode operation should be

- MODBUS ASCII :0110007200020400630032E2[cr][lf]
- MODBUS RTU 01100072000204006300320499

Response Message Frame

Factor	ASCII	RTU
Protocol Header	:(Colon)	-
Slave address	2 characters	8-Bit
Function code-16	2 characters	8-Bit
D-Register Hi	2 characters	8-Bit
D-Register Lo	2 characters	8-Bit
Address Count Hi	2 characters	8-Bit
Address Count Lo	2 characters	8-Bit
Error detecting	2 characters	16-Bit
Protocol Tail	2 characters (CR+LF)	-

Example

Without any trouble, response message will be.

- MODBUS ASCII :0110007200027B[cr][lf]
- MODBUS RTU 011000720002E1D3

7. D-REGISTER Description

D-Register is group of communication data to monitor and control all status of TEMP1500.

D-Register is grouped by consecutive 100 addresses based on its concerned function as shown below.

D-Register address	Group Name	Description	Read	Write
D0001~D0099	PROCESS	General operation process information	○	◆
D0100~D0199	FUNCTION	Operating Function setting	○	○
D0200~D0299	RESERVATION	Time & Reserve operation setting	○	△
D0300~D0399	ON/OFF SIGNAL	ON/OFF signal setting	○	○
D0400~D0499	INNER SIGNAL	INNER signal setting	○	○
D0500~D0599	ALARM SIGNAL	ALARM signal setting	○	○
D0600~D0699	TIME SIGNAL	TIME signal setting	○	○
D0700~D0799	PID	P.I.D setting	○	○
D0800~D0899	COMMUNICATION	Communication concerned information	○	△
D0900~D0999	INPUT	Sensor Input setting	○	○
D1000~D1099	OUTPUT	Control&retransmission Output setting	○	○
D1100~D1199	DO CONFIG1	DO(Digital Output) Relay setting-1	○	○
D1200~D1299	DO CONFIG2	DO(Digital Output) Relay setting-2	○	○
D1300~D1399	DI CONFIG1	DI(Digital Input) setting	○	○
D1400~D1499	DI CONFIG2	DI NAME input-1	○	○
D1500~D1599	DI CONFIG3	DI NAME input-2	○	○
D1600~D1699	INITIAL1	Initial system setting-1	○	○
D1700~D1799	INITIAL2	Initial system setting-2	○	○
D1800~D1899	INITIAL3	Initial system setting-3	○	○
D1900~D1999	INITIAL4	Initial system setting-4	○	○
D2000~D2099	PROGRAM	Program pattern profile setting	○	○
D2100~D2199	PATTERN INFO	Pattern profile information	○	◆
D2200~D3799	FILE1 ~ FILE17	Recorded Trend file information	○	◆
D3800~D3999	LOGIC SIG1~ LOGIC SIG2	Logical signal setting	○	○

☞ D-Register is composed of hexadecimal 4 digit (2-Byte).

- ○ : Available to read / write over all designated address range.
- △ : Available to read / write in part of designated address range.
- ◆ : Not available to read / write over all designated address range.

7.1 PROCESS

PROCESS group consists of fundamental parameter information concerned with operation process and status. Below table describes the detail Bit Map information of some parameter that indicates its status by Bit.

■ Bit Map information of TEMP1500

BIT	NOW.STS	IS.STS	TS.STS	ALM.STS	ONOFF.STS	DOCTR.STS	CTR.STS
	(D0010)	(D0011)	(D0012)	(D0013)	(D0014)	(D0015)	(D0016)
0	RESET	IS1	TS1	ALM1	T1	RUN	RUN
1	FIX	IS2	TS2	ALM2	T2	WAIT	WAIT
2	PROG	IS3	TS3	ALM3	T3	UP	UP
3	HOLD	IS4	TS4	ALM4	T4	DOWN	DOWN
4	WAIT	IS5	TS5		T5	SOAK	SOAK
5	AT	IS6	TS6		T6	FEND	FEND
6		IS7	TS7		T7	PTEND	PTEND
7		IS8	TS8			1REF	1REF
8						2REF	2REF
9							
10							
11							
12							
13							
14							
15							

BIT	D0.STS1	D0.STS2	D1.DATA	ADERR.STS	SYS.STS	LOGICLA.STS	SEGALM.STS
	(D0017)	(D0018)	(D0019)	(D0020)	(D0045)	(D0046)	(D0047)
0	D01	D017	D11	+OVER	DISP.COMERR	LOG1	SEGALM1
1	D02	D018	D12	-OVER	I0.COMERR	LOG2	SEGALM2
2	D03	D019	D13	S.OPN		LOG3	SEGALM3
3	D04	D020	D14			LOG4	SEGALM4
4	D05	D021	D15			LOG5	
5	D06	D022	D16			LOG6	
6	D07	D023	D17			LOG7	
7	D08	D024	D18			LOG8	
8	D09	D025	D19				
9	D010	D026	D110				
10	D011	D027	D111				
11	D012	D028	D112				
12	D013	D029	D113				
13	D014	D030	D114				
14	D015	D031	D115				
15	D016	D032	D116				

■ Bit Map status information D-Register

D-Reg.	Symbol	Descriptions
D0010	NOW.STS	Current operation status information.
D0011	IS.STS	INNER signal generating status information.
D0012	TS.STS	TIME signal generating status information.
D0013	ALM.STS	ALARM signal generating status information.
D0014	ONOFF.STS	ON/OFF signal generating status information.
D0015	DOCTR.STS	Other D0 signal generating status information.
D0016	CTR.STS	Displayed D0 signal status information on 2 nd Oper screen
D0017	USEROUT.STSL	Actual generating Do signal status through I/O board
D0018	USEROUT.STSH	
D0019	DI.DATA	DI Error outbreak status information.
D0020	ADERR.STS	Error status out of control range.
D0045	SYS.STS	The main control and display or the main control and I / O relay board Communication error occurs and the SD card used in the information indicates.
D0046	LOGICAL.STATUS	LOGICAL signal generating status information.
D0047	SEGALM.STS	SEGMENT ALARM signal generating status information.

■ Common process information D-Register for both PROG / FIX

D-Reg.	기 호	내 용
D0001	NPV	Current PV
D0002	NSP	Current SP
D0005	HMVOUT	Heating output volume.
D0006	CMVOUT	Cooling output volume.
D0007	MVOUT	Control output volume.
D0009	CPIDNO	Currently running PID number
D0024	RUN.TIME_H	Process time (Hour)
D0025	RUN.TIME_M	Process time (Minute)
D0026	RUN.TIME_S	Process time (Second)

■ PROGRAM operation process information D-Register

D-Reg.	기 호	내 용
D0027	RUN.PTNO	Currently running program pattern number
D0028	RUN.SEGNO	Currently running program segment number
D0029	NOW.PT.RPT	Count of current Repeat operation at running pattern
D0030	TOTAL.PT.RPT	Total Programmed Count of Repeat op. at running pattern
D0031	NOW.SEG.RPT	Count of current Repeat operation at running segment
D0032	TOTAL.SEG.RPT	Total Programmed Count of Repeat op. at running segment
D0033	NOW.SEGTM_H	Process time(High) of currently running segment
D0034	NOW.SEGTM_L	Process time(Low) of currently running segment
D0035	TOTAL.SEGTM_H	Programmed total time(High) of currently running segment
D0036	TOTAL.SEGTM_L	Programmed total time(Low) of currently running segment
D0039	PREV.TSP	Target Set Point of the preceding segment
D0040	NOW.TSP	Target Set Point of the current segment
D0050	USED PATTERN	Total number of programmed pattern
D0051	USED SEGMENT	Total number of programmed segment
D0052	DP	Decimal point position

7.2 FUNCTION Group

FUNCTION group consists of setting parameter D-register related with operational function and process.

■ Common Operational Function setting D-Register for both PROG / FIX

D-Reg.	Symbol	Descriptions
D0108	FUZZY	FUZZY Function (0:OFF, 1:ON)
D0112	KEYLOCK	KEYLOCK Function (0:OFF, 1:ON)
D0114	LIGHT.OFFTM	Backlight ON time
D0120	RESTRICT_MAIN	Main button restriction setting.
D0129	REC.OP	Saving operation setting(0:Auto, 1:Manual)
D0130	REC.CYCLE	Sampling time setting
D0136	AT	Carrying out Auto-Tuning (0:OFF, 1:ON)
D0147	DANGER.DISPLAY	Set to the usage of warning (0:OFF, 1:ON)
D0149	BUZ.ONOFF	Buzzer sound (0: UNUSE, 1: USE)
D0152	UTAG_USING	Tags enable (0:OFF, 1:ON)
D0153 ~ D0155	UTAG.NAME1~ UTAG.NAME3	Tag name is set up to 6 digits.

■ PROGRAM Operation & Function setting D-Register

D-Reg.	Symbol	Descriptions
D0100	SET.PTNO	Pattern Number to run program operation
D0140	WAIT.USE	WAIT Function (0:UNUSE, 1:USE)
D0142	WAIT_ZONE	WAIT ZONE setting
D0144	WAIT_TIME	WAIT TIME setting
D0146	WAIT.METHOD	Target of WAIT function (0:ALL, 1:SEG)

■ FIX Operation & Function setting D-Register

D-Reg.	Symbol	Descriptions
D0102	FIX.TSP	Set Point on FIX operation
D0106	SLOPE	UP/DOWN Setting the slope
D0109	TIME.OP	TIME OPERATION (0:UNUSE, 1:USE)
D0110	TIME.OP_H	HOUR setting for TIME OPERATION
D0111	TIME.OP_M	MINUTE & SEC setting for TIME OPERATION

■ OPERATION mode & performance setting D-Register

D-Reg.	Symbol	Process method	Setting	Description
D0101	COM.OPMODE	RUN	1	Start running PROG/FIX Oper.
		HOLD	2	HOLD ON/OFF
		STEP	3	Segment STEP
		STOP	4	Stop PROG/FIX Operation
D0104	OP.MODE	PROG	0	Set PROG Operation MODE
		FIX	1	Set FIX Operation MODE
D0105	PWR.MODE	STOP	0	Not using Power-Mode
		COLD	1	COLD MODE
		HOT	2	HOT MODE

☞ To activate PROG operation RUN or FIX operation RUN, TEMP1500 should be in individual corresponding STOP(PROG STOP/FIX STOP) state. For example, to activate PROG operation RUN from currently operating FIX RUN state, convert the operation state to PROG STOP (D0104 = 0000, D0102 = 0004) first, then you can activate PROG operation RUN.

7.3 RESERVATION Group

RESERVATION TEMP1500 hours of group identification, and book set, PROGRAM driver's start time and end time of operation consists of related D-Register.

■ TIME setting and information D-Register

D-Reg.	Symbol	Description	Read	Write
D0201	NOW.YEAR	Current YEAR installed in TEMP1500	○	×
D0202	NOW.MONTH	Current MONTH installed in TEMP1500	○	×
D0203	NOW.DAY	Current DAY installed in TEMP1500	○	×
D0204	NOW.AMPM	Current TIME-AM/PM installed in TEMP1500	○	×
D0205	NOW.HOUR	Current HOUR installed in TEMP1500	○	×
D0206	NOW.MIN	Current MN. installed in TEMP1500	○	×
D0207	C.YEAR	Current YEAR setting in TEMP1500	×	○
D0208	C.MONTH	Current MONTH setting in TEMP1500	×	○
D0209	C.DAY	Current DAY setting in TEMP1500	×	○
D0210	C.AMPM	Current TIME-AM/PM setting in TEMP1500	×	○
D0211	C.HOUR	Current HOUR setting in TEMP1500	×	○
D0212	C.MIN	Current MN. setting in TEMP1500	×	○
D0213	R.YEAR	YEAR setting for RESERVE Operation	○	○
D0214	R.MONTH	MONTH setting for RESERVE Operation	○	○
D0215	R.DAY	DAY setting for RESERVE Operation	○	○
D0216	R.AMPM	TIME-AM/PM setting for RESERVE Operation	○	○
D0217	R.HOUR	HOUR setting for RESERVE Operation	○	○
D0218	R.MIN	MIN. setting for RESERVE Operation	○	○

■ RESERVE Operation

D-Reg.	Symbol	Operation	Setting	Description
D0200	RESERVE	OFF	0	Release RESERVE Oper.
		ON	1	Set RESERVE Oper.

■ PROGRAM Start time and end time running

D-Reg.	Symbol	Description
D0260	TIME_VALID	Show start time and end time (0: Normal, 1:---.-)
D0261	START_YEAR	Setting start time (Year)
D0262	START_MON	Setting start time (Month)
D0263	START_DAY	Setting start time (Day)
D0264	START_HOUR	Setting start time (Hour)
D0265	START_MIN	Setting start time (Min)
D0266	END_YEAR	Setting end time (Year)
D0267	END_MON	Setting end time (Month)
D0268	END_DAY	Setting end time (Day)
D0269	END_HOUR	Setting end time (Hour)
D0270	END_MIN	Setting end time (Min)

7.4 ON/OFF SIGNAL Group

This setting parameter D-register group is used to establish 6 ON/OFF SIGNALs.

■ ON/OFF SIGNAL setting D-Register

D-Reg.	Symbol	Description
D0301	T1.LSP	Low SP for ON/OFF SIGNAL T1
D0302	T1.MSP	Middle SP for ON/OFF SIGNAL T1
D0303	T1.HSP	High SP for ON/OFF SIGNAL T1
D0304	T1.HDV	High zone Deviation for operating Point at High Zone T1
D0305	T1.LDV	Low zone Deviation for operating Point at Low Zone T1
.	.	.
.	.	.
.	.	.
D0336	T6.LSP	Low SP for ON/OFF SIGNAL T6
D0337	T6.MSP	Middle SP for ON/OFF SIGNAL T6
D0338	T6.HSP	High SP for ON/OFF SIGNAL T6
D0339	T6.HDV	High zone Deviation for operating Point at High Zone T6
D0340	T6.LDV	Low zone Deviation for operating Point at Low Zone T6

7.5 INNER SIGNAL Group

This setting parameter D-register group is used to establish 8 INNER SIGNALs.

■ INNER SIGNAL setting D-Register

D-Reg.	Symbol	Descriptions
D0401	IS1.TYPE	Object Type of Target of INNER SIGNAL1 (0:SP, 1:PV, 2:MV)
D0402	IS1.BAND	Direction Band of INNER SIGNAL1 (0:IN-B, 1:OUT-B)
D0403	IS1.RH	Range High of INNER SIGNAL1
D0404	IS1.RL	Range Low of INNER SIGNAL1
D0405	IS1.DYT	DELAY TIME of INNER SIGNAL1
.	.	.
.	.	.
.	.	.
D0443	IS8.TYPE	Object Type of Target of INNER SIGNAL8 (SP/PV/MV)
D0444	IS8.BAND	Direction Band of INNER SIGNAL8 (IN-B/OUT-B)
D0445	IS8.RH	Range High of INNER SIGNAL8
D0446	IS8.RL	Range Low of INNER SIGNAL8
D0447	IS8.DYT	DELAY TIME of INNER SIGNAL8

7.6 ALARM SIGNAL Group

This setting parameter D-register group is used to establish 4 ALARM signals and 8 SEGMENT ALARM.

■ ALARM signal setting D-Register

D-Reg.	Symbol	Descriptions
D0501	ALM.OP	Condition of ALARM Operation (0:RUN, 1:ALWAYS)
D0505	ALM1.TYPE	Type of ALARM signal 1
D0506	ALM1.POINT	Target Point of ALARM signal 1
D0507	ALM1.H_POINT	Limit High point of ALARM signal 1
D0508	ALM1.L_POINT	Limit Low point of ALARM signal 1
D0509	ALM1.HYS	Hysteresis of ALARM signal 1
D0510	ALM1.DYT	DELAY TIME of ALARM signal 1
.	.	.
.	.	.
.	.	.
D0526	ALM4.TYPE	Type of ALARM signal 4
D0527	ALM4.POINT	Target Point of ALARM signal 4
D0528	ALM4.H_POINT	Limit High point of ALARM signal 4
D0529	ALM4.L_POINT	Limit Low point of ALARM signal 4
D0530	ALM4.HYS	Hysteresis of ALARM signal 4
D0531	ALM4.DYT	DELAY TIME of ALARM signal 4

■ 세그먼트 경보시그널 관련 D-Register

D-Reg.	Symbol	Descriptions
D0540	SA1.TYPE	Type of SEGMENT ALARM signal 1
D0541	SA1.POINT	Target Point of SEGMENT ALARM signal 1
D0542	SA1.H_POINT	Limit High point of SEGMENT ALARM signal 1
D0543	SA1.L_POINT	Limit Low point of SEGMENT ALARM signal 1
D0544	SA1.HYS	Hysteresis of SEGMENT ALARM signal 1
D0545	SA1.DYT	DELAY TIME of SEGMENT ALARM signal 1
.	.	.
.	.	.
.	.	.
D0582	SA8.TYPE	Type of SEGMENT ALARM signal 8
D0583	SA8.POINT	Target Point of SEGMENT ALARM signal 8
D0584	SA8.H_POINT	Limit High point of SEGMENT ALARM signal 8
D0585	SA8.L_POINT	Limit Low point of SEGMENT ALARM signal 8
D0586	SA8.HYS	Hysteresis of SEGMENT ALARM signal 8
D0587	SA8.DYT	DELAY TIME of SEGMENT ALARM signal 8

7.7 TIME SIGNAL Group

This setting parameter D-register group is used to establish 19 TIME SIGNALs.

■ TIME SIGNAL setting D-Register

D-Reg.	Symbol	Descriptions
D0601	TS2DYTM_H	DELAY TIME (HOUR) of generating TIME SIGNAL 2.
D0602	TS2DYTM_L	DELAY TIME (MIN. & SEC.) of generating TIME SIGNAL 2.
D0603	TS2KPTM_H	OPER.TIME (HOUR) to keep generating TIME SIGNAL 2.
D0604	TS2KPTM_L	OPER.TIME (MIN. & SEC.) to keep generating TIME SIGNAL 2.
.	.	.
.	.	.
.	.	.
D0673	TS20DYTM_H	DELAY TIME (HOUR) of generating TIME SIGNAL 20.
D0674	TS20DYTM_L	DELAY TIME (MIN. & SEC.) of generating TIME SIGNAL 20.
D0675	TS20KPTM_H	OPER.TIME (HOUR) to keep generating TIME SIGNAL 20.
D0676	TS20KPTM_L	OPER.TIME (MIN. & SEC.) to keep generating TIME SIGNAL 20.

7.8 PID Group

This setting parameter D-register group is used to establish 6 PID GROUP

■ PID Application range setting D-Register

D-Reg.	Symbol	Descriptions
D0701	RP1	Reference Point 1 (T1) to define PID ZONE.
D0702	RP2	
D0703	RP3	
D0704	RP4	
D0706	RHYS	Selects hysteresis when ZONE PID.
D0707	RDEV	Sets deviation for selecting deviation PID.
D0709	CMOD	Select the control method. (0:D.PV, 1:D.DV)
D0711	AT.POINT	Auto-tuning sets the reference value.
D0712	AT.DISPLAY	Setting to display or hide AT KEY. (0:HIDE, 1:DISPLAY)
D0713	PID.OPMODE	Select sets of PID. (0:SEG, 1:ZONE)
D0714	PID.APP	ZONE PID sets of selection criteria. (0:PV, 1:SP)

■ General(Heating) PID setting D-Register

D-Reg.	Symbol	Descriptions
D0717	1_HP	Proportional band of PID1
D0718	1_HI	Integral time of PID1
D0719	1_HD	Differential time of PID1
D0720	1_HOH	Control Output High limit of PID1
D0721	1_OL	Control Output Low limit of PID1
D0722	1_MR	Integral time of PID1 is set manually.
D0723	1_HHYS	PID1 the ON / OFF control hysteresis High limit is set at.
D0724	1_LHYS	PID1 the ON / OFF control hysteresis at the Low setting.
.	.	.
.	.	.
.	.	.
D0757	6_HP	Proportional band of PID6
D0758	6_HI	Integral time of PID6
D0759	6_HD	Differential time of PID6
D0760	6_HOH	Control Output High limit of PID6
D0761	6_OL	Control Output Low limit of PID6
D0762	6_MR	Integral time of PID6 is set manually.
D0763	6_HHYS	PID6 the ON / OFF control hysteresis High limit is set at.
D0764	6_LHYS	PID6 the ON / OFF control hysteresis at the Low setting.

■ Cooling PID setting D-Register

D-Reg.	Symbol	Descriptions
D0766	1._CP	Proportional band of Cooling PID1
D0767	1._CI	Integral time of Cooling PID1
D0768	1._CD	Differential time of Cooling PID1
.	.	.
.	.	.
.	.	.
D0781	6._CP	Proportional band of Cooling PID6
D0782	6._CI	Integral time of Cooling PID6
D0783	6._CD	Differential time of Cooling PID6
D0785	1.DB	Setting of the DEAD BAND for PID 1 in H/C TYPE
.	.	.
.	.	.
.	.	.
D0790	6.DB	Setting of the DEAD BAND for PID 6 in H/C TYPE
D0792	HCHYS	Setting the hysteresis value to be applied to internal control MV in Heating&Cooling, ON/OFF control
D0866	1.HOL	[HEAT]Set the upper limit of the output PID1.
.	.	.
.	.	.
.	.	.
D0877	6.COL	[COOL]Set the upper limit of the output PID6.

7.9 COMMUNICATION Group

This group is consists of information parameter D-Register concerned communication.

■ COMMUNICATION concerned information D-Register

D-Reg.	Symbol	Descriptions
D0801	COM2.PROTOCOL	[COM2] Communication Protocol information
D0802	COM2.BPS	[COM2] Communication speed (Baud Rate) information.
D0803	COM2.PARITY	[COM2] Parity information.
D0804	COM2.STOP.BIT	[COM2] Stop Bit information.
D0805	COM2.DATA.LENGTH	[COM2] Data Length information.
D0806	COM2.ADDRESS	[COM2] Slave Address information.
D0807	COM2.RESPONSE	[COM2] Response Time information.
D0808	COMM.LOCK	Set to lock operation for related communication COMMAND transmitting / receiving
D0809	COM4.BPS	[COM4] Communication speed (Baud Rate) information.
D0810	SYNC.MST	SYNC Master (0:OFF, 1:ON)

7.10 INPUT Group

This INPUT group is used for setting parameter D-Register for sensor and its bias.

■ INPUT setting D-Register

D-Reg.	Symbol	Descriptions
D0901	SENGP	Select the sensor group. (0:T/C, 1:RTD, 2:DCV)
D0902	SENTP	Setting the type of sensor.
D0903	UNIT	Setting the display unit.
D0904	DP	Set-point position.
D0905	TCSL	T/C select show (0:T/C, 1:T/C+RJC, 2:RJC)
D0906	SOPN.SEL	Sensors-open, pv select the direction. (0:UNSET, 1:UP, 2:DOWN)
D0907	INRH	Setting the High limit range of use.
D0908	INRL	Setting the Low limit range of use.
D0909	BIAS	Setting the previous range revision value.
D0910	INFL	Removes noise when measuring input includes noise of high frequency.
D0912	INSH	Scale sets the High limit.
D0913	INSL	Scale sets the Low limit.
D0916	SPLMT.H	Setting the upper limit of SP LIMIT.
D0917	SPLMT.L	Setting the lower limit of SP LIMIT.
D0931~D0938	BP1.DDV~BP8.DDV	Setting revision temperature at each standard temperature.
D0939~D0946	BP1.DPV~BP8.DPV	Setting each standard temperature.
D0970~ D0971	UNITNAME_1~ UNITNAME_2	Setting the DCV sensor display unit name.

7.11 OUTPUT Group

This INPUT group is used for setting parameter D-Register for control output and retransmission.

■ Control output and retransmission setting D-Register

D-Reg.	Symbol	Descriptions
D1002	DIR	Select the direction of behavior.(0:REV, 1:FWD)
D1003	HCT	[HEAT]Sets the output cycle.
D1004	HATG	[HEAT]Auto-Tuning GAIN value for Manual PID.
D1005	HPO	[HEAT]Output is in an emergency setting.
D1006	CCT	[COOL]Sets the output cycle.
D1007	CATG	[COOL]Auto-Tuning GAIN value for Manual PID.
D1008	CPO	[COOL]Output is in an emergency setting.
D1009	ARW	ARW(Anti Reset Wind-up) sets the value of prevention.
D1011	UPOPR	Change the setting up of the control output.
D1012	DNOPR	Change the setting of control output is falling.
D1015	RETT	Target object of transmission (0:PV, 1:SP, 2:MV)
D1016	RETH	Range High of transmission
D1017	RETL	Range Low of transmission
D1031	OUT1.TYPE	Setting the ouput terminal of OUT 1.
D1032	OUT2.TYPE	Setting the ouput terminal of OUT 2.
D1033	OUT3.TYPE	Setting the ouput terminal of OUT 3.
D1034	OUT4.TYPE	Setting the ouput terminal of OUT 4.
D1037	OUT1.MODE	Setting the output type of OUT 1.(0:SSR, 1:SCR)
D1038	OUT2.MODE	Setting the output type of OUT 2.(0:SSR, 1:SCR)
D1039	OUT3.MODE	Setting the output type of OUT 3.(0:SSR, 1:SCR)
D1040	OUT4.MODE	Setting the output type of OUT 4.(0:SSR, 1:SCR)

7.12 DO CONFIG Group

DO CONFIG group consists of setting and information parameter D-Register related to establish RELAY number on I/O board to generate signal and its sub setting for auxiliary Digital Output.

■ DO CONFIG setting and information D-Register

D-Reg.	Symbol	Descriptions
D1101~D1108	IS1.RLY~IS8.RLY	RELAY No.on I/O for INNER SIGNAL.
D1109~D1116	TS1.RLY~TS8.RLY	RELAY No.on I/O for TIME SIGNAL.
D1117~D1120	ALM1.RLY~ALM4.RLY	RELAY No.on I/O ALARM SIGNAL.
D1121~D1124	SA1.RLY~SA4.RLY	RELAY No.on I/O SEGMENT ALARM SIGNAL.
D1125~D1138	T1.RLY~T7.DYT	RELAY No.on I/O and DELAY TIME for ON/OFF SIGNAL.
D1139~D1154	D11.RLY~D116RLY	RELAY No.on I/O for DI SIGNAL.
D1155~D1166	USER.RLY1~USER.RLY12	RELAY No.on I/O for MANUAL SIGNAL.
D1167	USER.RLY_ON/OFF	Switch "ON" the relay for the corresponding number manually.
D1168~D1175	LOG1.RLY ~ LOG8.RLY	RELAY No.on I/O for LOGICAL SIGNAL
D1176,D1177	HOLD.RLY, HOLD.OPT	RELAY No.on I/O and OPERATION TIME for ON/OFF SIGNAL.
D1201,D1202	RUN.RLY,RUN.DYT	RELAY No.on I/O and DELAY TIME for RUN SIGNAL.
D1203,D1204	SOPN.RLY,SOPN.KPT	RLY No.on I/O and KEEP TIME for SENSOR-OPEN SIGNAL.
D1205,D1206	WAIT.RLY,WAIT.KPT	REALY No.on I/O and KEEP TIME for WAIT SIGNAL.
D1207, D1208	FIXTIMER.RLY,FIXTIMER.DEV	RELAY No.on I/O and DEVIATION for FIXTIMER SIGNAL
D1209, D1210	FIXTIMER.DLY,FIXTIMER.OPT	DELAY TIME and OPERATION TIME for FIXTIMER SIGNAL
D1211,D1212,D1213	UP.RLY,UP.DEV, UP.DEVSEL	RELAY No.on I/O, DEVIATION and Operating conditions for UP SIGNAL. (Operating conditions 0:[TSP-NSP] ,1:[TSP-NPV])
D1214,D1215	SOAK.RLY,SOAK.KPT	REALY No.on I/O and KEEP TIME for SOAK SIGNAL.
D1216,D1217,D1218	DOWN.RLY,DOWN.DEV, DOWN.DEVSEL	RELAY No.on I/O, DEVIATION and Operating conditions for DOWN SIGNAL. (Operating conditions 0:[TSP-NSP] ,1:[TSP-NPV])
D1219,D1220	1REF.RLY,1REF.DYT	RELAY No.on I/O and DELAY TIME for 1 st Refrigerator oper.
D1221,D1222	2REF.RLY,2REF.DYT	RELAY No.on I/O and DELAY TIME for 2 nd Refrigerator oper.
D1223,D1224	ERROR.RLY,ERROR.KPT	REALY No.on I/O and KEEP TIME for ERROR SIGNAL.
D1225,D1226,D1227	FEND.RLY,FEND.DLT FEND.OPT	RLY No.on I/O, DELAY TIME, OPERATION TIME for FIX-END SIGNAL.
D1228,D1229,D1230	PTEND.RLY,PTEND.DLT PTEND.OPT	RLY No.on I/O, DELAY TIME, OPERATION TIME for PROGRAM PTN-END SIGNAL.
D1231,D1232	UKEY.RLY,UKEY.OPT	RELAY No.on I/O for USER KEY SIGNAL.

7.13 DI CONFIG Group

DI CONFIG group consists of setting parameter D-Register for DI ERROR and its name.

■ DI CONFIG setting D-Register

D-Reg.	Symbol	Descriptions
D1301	DI1.OP_MODE	OPERATION MODE when DI 1 ON. (0:ERROR, 1:RUN/STOP)
D1302	DI2.OP_MODE	OPERATION MODE when DI 2 ON. (0:ERROR, 1:HOLD)
D1303	DI3.OP_MODE	OPERATION MODE when DI 3 ON. (0:ERROR, 1:STEP)
D1304	DI4.OP_MODE	OPERATION MODE when DI 4 ~ 16 ON (0:ERROR, 1:PATTERN SELECTION)
D1305	DI.DET.TIME	DETECT TIME to recognize DI ERROR from actual occurrence
D1306	BUZ.TIME	Sets time for DI Error buzzer.
D1309,D1310	DI1.OP,DI1.DYT	DI 1 OPERATION after detecting and DELAY TIME
.	.	.
.	.	.
.	.	.
D1339,D1340	DI16.OP,DI16.DYT	DI 16 OPERATION after detecting and DELAY TIME
D1342	DI1.DETECT	Setting the DI1 sensing method (0:A-TYPE, 1:B-TYPE)
.	.	.
.	.	.
.	.	.
D1357	DI16.DETECT	Setting the DI16 sensing method (0:A-TYPE, 1:B-TYPE)
D1401~D1412	DI1.NAME1~DI1.NAME12	Setting the DI1 error name.
.	.	.
.	.	.
.	.	.
D1585~D1596	DI16.NAME1~DI16.NAME12	Setting the DI16 error name

7.14 INITIAL Group

INITIAL group consists of setting parameter D-Register for system initial configuration.

INITIAL setting D-Register

D-Reg.	Symbol	Descriptions
D1601	LANGUAGE	Setting the language (0:ENG, 1:KOR, 2:CHN)
D1603	UKEY.USE	Setting the USER KEY(0:UNUSED, 1:USE)
D1604	UKEY.KIND	Setting the USER KEY type. (0:UNUSE, 1:USE, 2:Buz.Off, 3:User set.)
D1606~D1609	UKEY.NAME1~UKEY.NAME4	Set the name of USER KEY.
D1611~D1622	INFORM1.NAME1 ~INFORM1.NAME13	Name of INIT INFORMATION 1 when setting 'TEXT' on DISPLAY MODE.
.	.	.
.	.	.
.	.	.
D1637~D1649	INFORM3.NAME1 ~INFORM3.NAME13	Name of INIT INFORMATION 3 when setting 'TEXT' on DISPLAY MODE.
D1701~D1758	LAMP_IS1~LAMP_DI16	STATUS DISPLAY LAMP.

LED Name setting D-Register

D-Reg.	Symbol	Descriptions
D1801 ~ D1803	LED1.NAME1 ~ LED1.NAME3	Set the name of LED1
.	.	.
.	.	.
.	.	.
D1973 ~ D1975	LED58.NAME1 ~ LED58.NAME3	Set the name of LED58

7.15 PROGRAM PATTERN Group and Setting

7.15.1 PROGRAM

PROGRAM group consists of parameter D-Register to arrange program PATTERN organized by each segment profile. Each segment should be established step by step.

■ Program PATTERN setting D-Register

D-Reg.	Symbol	Range	Description
D2001	COM_PTNO	1~80	Program PATTERN number to Read or Write
D2002	COM_SEGNO	0	To Read or Write in D2045~D2067
		1~99	Segment number to Read or Write
D2003	PTCOPY_START	-	First target (START) pattern number to paste
D2004	PTCOPY_END	-	Last target (END) pattern number to paste
D2005	PTDEL_START	-	First target (START) pattern number to delete
D2006	PTDEL_END	-	Last target (END) pattern number to delete
D2007	TRIGGER	1	INIT : Initialize D2001~D2008 to '0'
		2	READ : Read profiles in D2001 and D2002
		3	WRITE : Write profiles in D2001 and D2002
		4	PT COPY : Copy PTN in D2001 to PTN designated in D2003~2004
		5	PT DEL : Delete PTN designated in D2005~D2006
		6	PT NAME READ : Read PTN NAME in D2001
		7	PT NAME WRITE : Write PTN NAME in D2001
		8	ALL PT : Write pattern profile at D2001 into D2200
D2008	ANSWER	0	FULL : Excessive number of pattern or segment setting
		1	DONE : Normally accessed of D2007(TRIGGER) command
		2	PT EMPTY : No profile in designated pattern
		3	SEG EMPTY : No profile in designated segment
		4	PT RUN : Program RUN state of designated PTN
		5	PARA ERROR : Program setting Error of D2001~D2007
D2011~D2022	PATTERN_NAME1~12	-	Pattern NAME to Read or Write
D2026	TSP	-	Target Set Point(TSP) to Read or Write
D2027	SEG.TIME_H	-	Target Process time (HOUR) of segment to Read or Write
D2028	SEG.TIME_L	-	Target Process time (MIN & SEC) of segment to Read or Write
D2029	TS1	-	TS1 to Read or Write
D2030	TS2	-	TS2 to Read or Write
D2031	TS3	-	TS3 to Read or Write
D2032	TS4	-	TS4 to Read or Write
D2033	TS5	-	TS5 to Read or Write
D2034	TS6	-	TS6 to Read or Write
D2035	TS7	-	TS7 to Read or Write
D2036	TS8/AUX_OUT	-	TS8 or AUX to Read or Write
D2037	SEGAL1	-	SEGMENT ALARM1 to Read or Write
D2038	SEGAL2	-	SEGMENT ALARM2 to Read or Write
D2039	SEGAL3	-	SEGMENT ALARM3 to Read or Write
D2040	SEGAL4	-	SEGMENT ALARM4 to Read or Write
D2041	SEG_PID	-	SEGMENT PID to Read or Write

■ PROGRAM and its REPEAT operation setting D-Register

D-Reg.	Symbol	Descriptions
D2045	START.CODE	START CODE for operation (0:TPV, 1:SPV, 2:SSP)
D2046	START.SP	START SSP
D2050	PT.RPT	Count number for PATTERN REPEAT (0:Infinitely, 1 ~ 999)
D2051	PT.EMOD	PATTERN END MODE (0:RESET, 1:SEG HOLD, 2:LINK RUN)
D2052	LINK.PT	LINK PATTERN (1 ~ 80)
D2056	SEG_RPT.S1	SEGMENT REPEAT START-1
D2057	SEG_RPT.E1	SEGMENT REPEAT END-1
D2058	SEG_RPT.C1	SEGMENT REPEAT COUNT-1
D2059	SEG_RPT.S2	SEGMENT REPEAT START-2
D2060	SEG_RPT.E2	SEGMENT REPEAT END-2
D2061	SEG_RPT.C2	SEGMENT REPEAT COUNT-2
D2062	SEG_RPT.S3	SEGMENT REPEAT START-3
D2063	SEG_RPT.E3	SEGMENT REPEAT END-3
D2064	SEG_RPT.C3	SEGMENT REPEAT COUNT-3
D2065	SEG_RPT.S4	SEGMENT REPEAT START-4
D2066	SEG_RPT.E4	SEGMENT REPEAT END-4
D2067	SEG_RPT.C4	SEGMENT REPEAT COUNT-4

7.15.2 How to READ program PATTERN

▶ Below describes process step to read programmed PATTERN profile in TEMP1500.

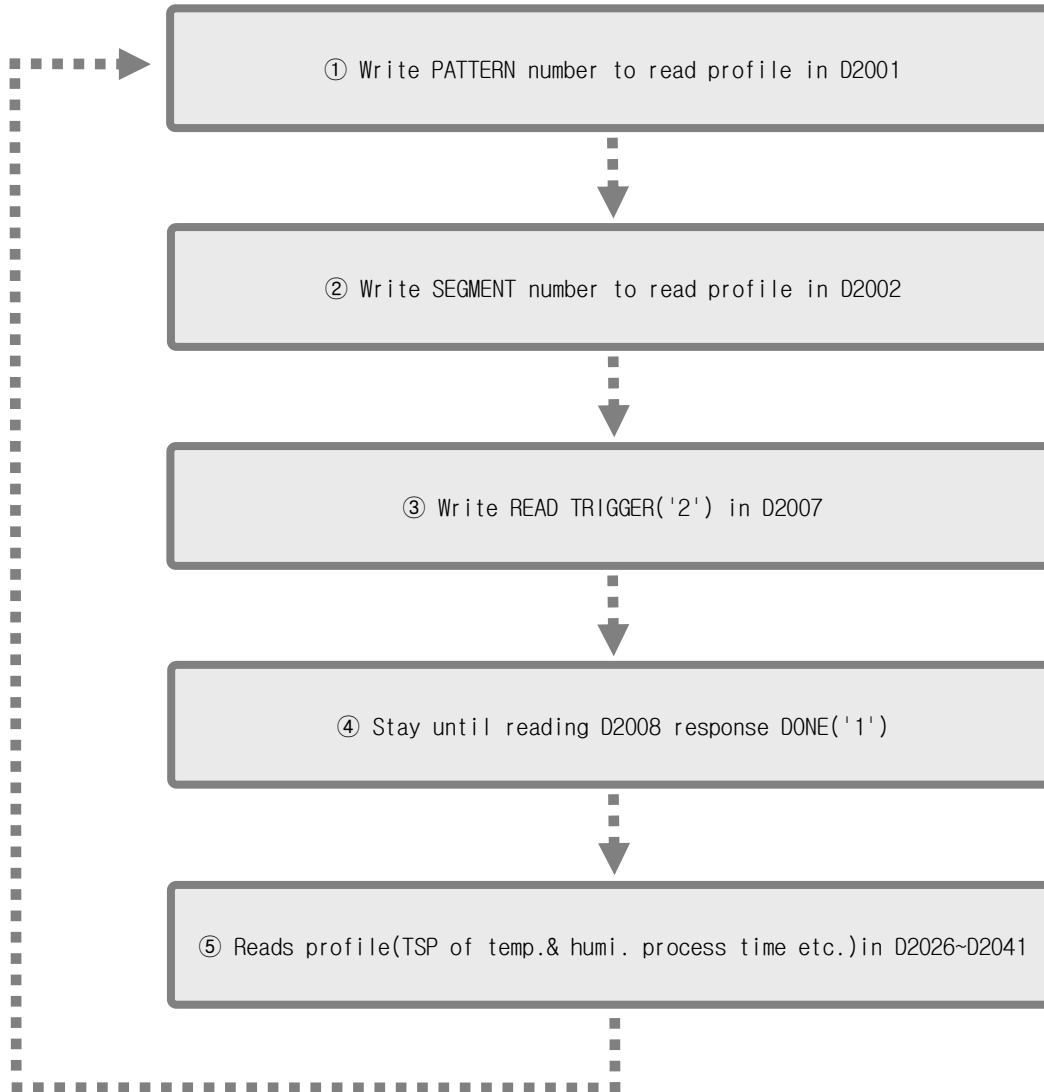

Above process step ① ~ ⑤ is used to read 'ONE SEGMENT' profile among all in programmed pattern. To read many segments, reiterate ① ~ ⑤ process step by changing segment number. Setting '0' in D2002 at process step ② will read profile in D2045~D2067.

7.15.3 How to WRITE program PATTERN

▶ Below describes process step to write programming PATTERN profile in TEMP1500.

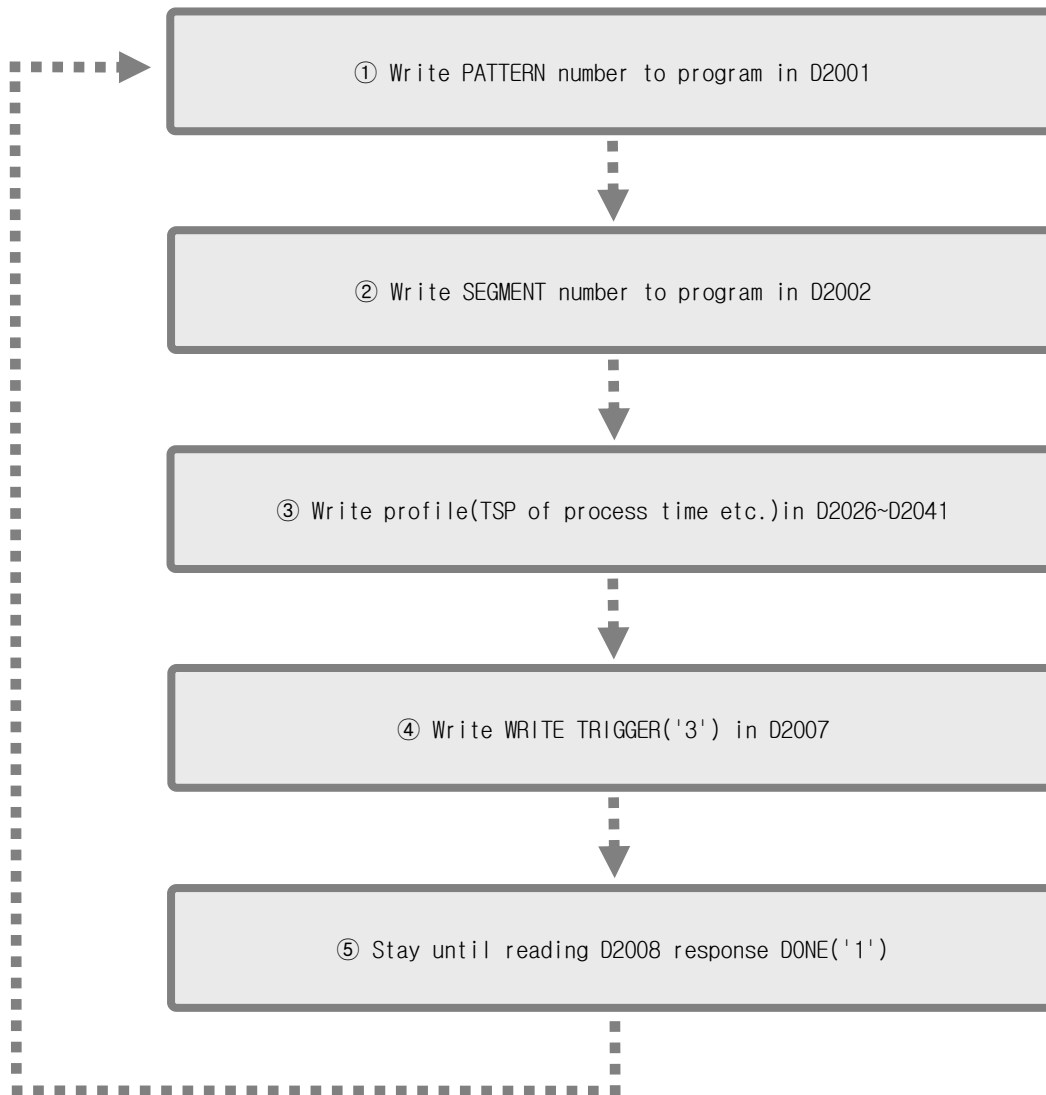

Above process step ① ~ ⑤ is used to write 'ONE SEGMENT' profile among all in programmed pattern. Reiterate ① ~ ⑤ process step by changing segment number to write many segments.

▶ Below describes process step to write program in D2145~D2167.

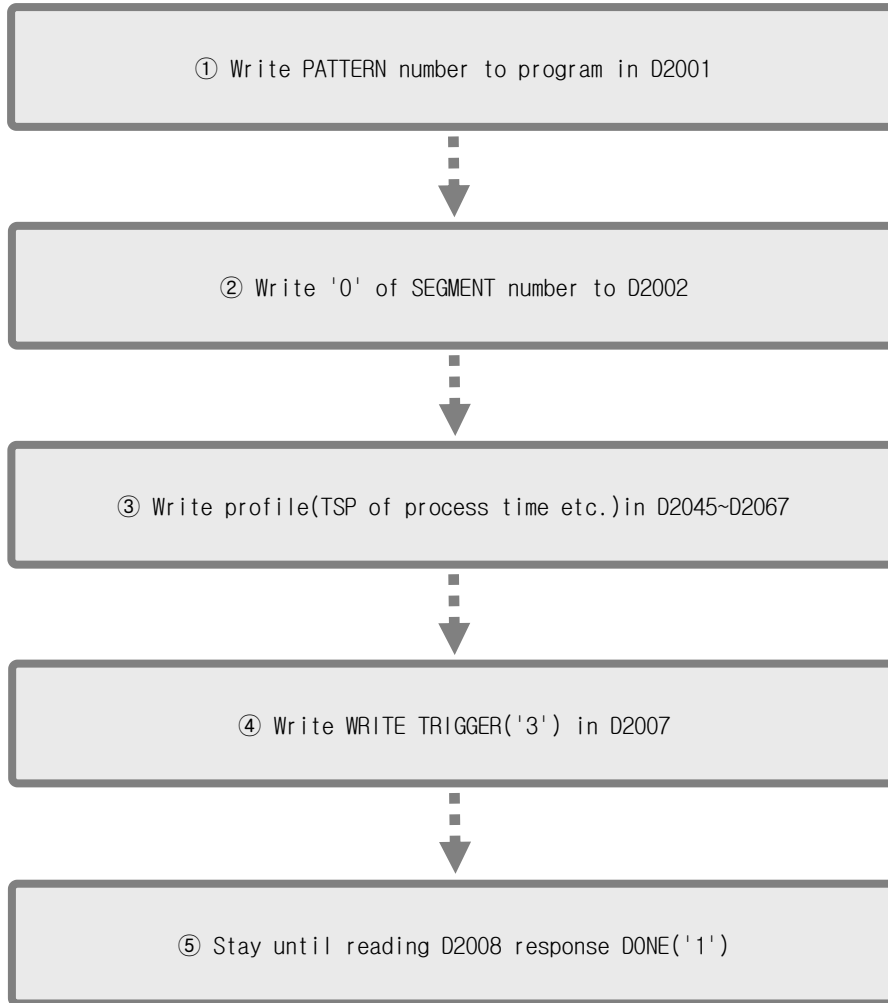

7.15.4 FILE EDIT (PATTERN COPY / DELETE)

▶ Below describes step to copy pattern.

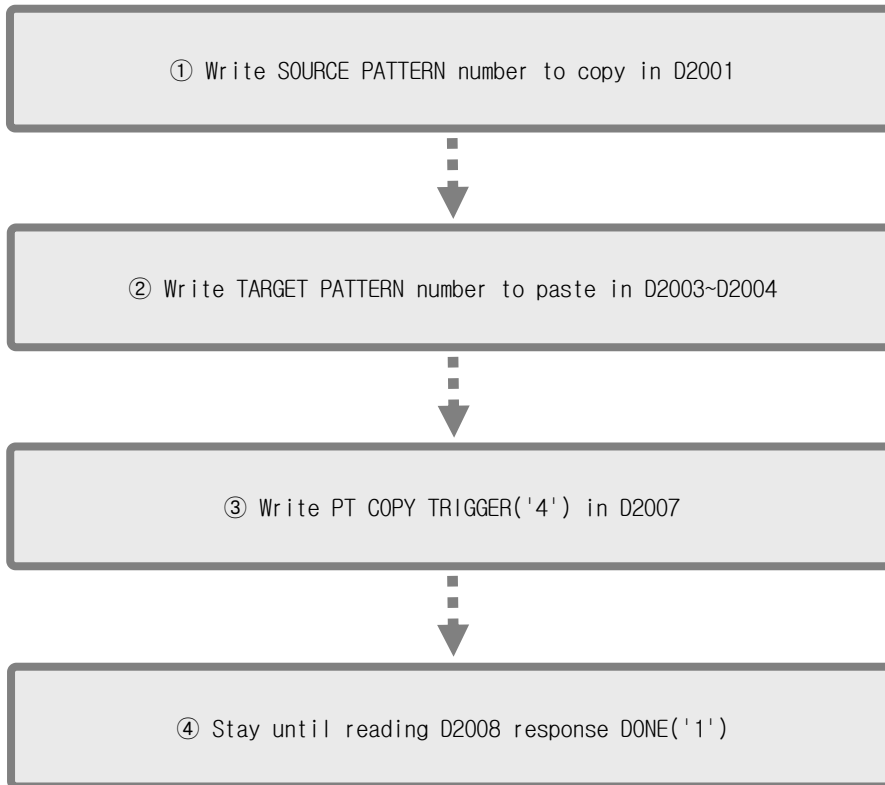

▶ Below describes step to delete pattern.

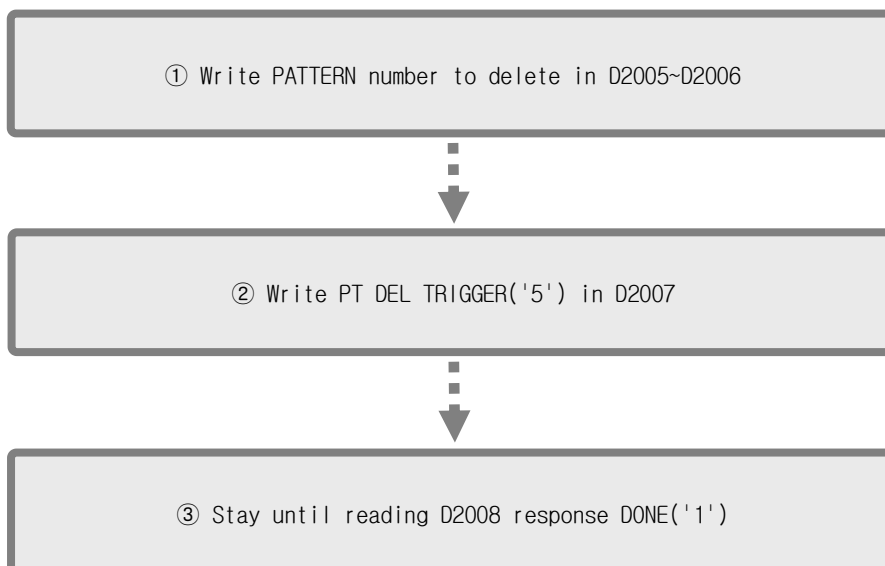

7.16 PATTERN INFO

PATTERN INFO group consists of programmed pattern and segment information parameter D-Register.

■ Programmed pattern and segment information D-Register

D-Reg.	Symbol	Descriptions
D2101	NPT1	The number of programmed SEGMENT in PATTERN no.1
.	.	.
.	.	.
D2180	NPT80	The number of programmed SEGMENT in PATTERN no.80

7.17 FILE

FILE group consists of profile information of programmed pattern parameter D-Register.

■ FILE information D-Register

D-Reg.	Symbol	Descriptions
D2201~D2299	C.TSP1~C.TSP99	SP in reading pattern.
D2301~D2399	C.SRTIME_H1~C.SRTIME_H99	Total operation time (Hour) in reading pattern.
D2401~D2499	C.SRTIME_L1~C.SRTIME_L99	Total operation time (Minute&Second) in reading pattern.
D2501~D2599	C.TS1_1~C.TS1_99	TS1 in reading pattern.
D2601~D2699	C.TS2_1~C.TS2_99	TS2 in reading pattern.
D2701~D2799	C.TS3_1~C.TS3_99	TS3 in reading pattern.
D2801~D2899	C.TS4_1~C.TS4_99	TS4 in reading pattern.
D2901~D2999	C.TS5_1~C.TS5_99	TS5 in reading pattern.
D3001~D3099	C.TS6_1~C.TS6_99	TS6 in reading pattern.
D3101~D3199	C.TS7_1~C.TS7_99	TS7 in reading pattern.
D3201~D3299	C.TS8_1~C.TS8_99	TS8 or AUX in reading pattern.
D3301~D3399	C.SEGAL1_1~C.SEGAL1_99	SEGMENT ALARM1 in reading pattern.
D3401~D3499	C.SEGAL2_1~C.SEGAL2_99	SEGMENT ALARM2 in reading pattern.
D3501~D3599	C.SEGAL3_1~C.SEGAL3_99	SEGMENT ALARM3 in reading pattern.
D3601~D3699	C.SEGAL4_1~C.SEGAL4_99	SEGMENT ALARM4 in reading pattern.
D3701~D3799	C.SEGPID_1~C.SEGPID_99	SEGMENT PID in reading patten.

7.18 LOGIC SIG Group

LOGIC SIG group consists of setting parameter D-Register for logical signal configuration.

■ LOGICAL SIGNAL setting D-Register

D-Reg.	Symbol	Descriptions
D3801	LOG1_SIGNAL1	Set the application object 1 of the LOGIC SIG 1.
D3802	LOG1_ACT1	Set the output method 1 of the LOGIC SIG 1.
D3803	LOG1_DYT1	Set the delay time 1 of the LOGIC SIG 1.
.	.	.
D3805	LOG1_SIGNAL4	Set the application object 4 of the LOGIC SIG 1.
D3806	LOG1_ACT4	Set the output method 4 of the LOGIC SIG 1.
D3807	LOG1_DYT4	Set the delay time 4 of the LOGIC SIG 1.
D3808	LOG1_OPERAND1	Set the operator 1 of LOGIC SIG 1.
D3809	LOG1_OPERAND2	Set the operator 2 of LOGIC SIG 1.
D3810	LOG1_OPERAND3	Set the operator 3 of LOGIC SIG 1.
.	.	.
.	.	.
.	.	.
D3901	LOG8_SIGNAL1	Set the application object 1 of the LOGIC SIG 8.
D3902	LOG8_ACT1	Set the output method 1 of the LOGIC SIG 8.
D3903	LOG8_DYT1	Set the delay time 1 of the LOGIC SIG 8.
.	.	.
.	.	.
D3905	LOG8_SIGNAL4	Set the application object 4 of the LOGIC SIG 8.
D3906	LOG8_ACT4	Set the output method 4 of the LOGIC SIG 8.
D3907	LOG8_DYT4	Set the delay time 4 of the LOGIC SIG 8.
D3908	LOG8_OPERAND1	Set the operator 1 of LOGIC SIG 8.
D3909	LOG8_OPERAND2	Set the operator 2 of LOGIC SIG 8.
D3910	LOG8_OPERAND3	Set the operator 3 of LOGIC SIG 8.

D-Register 0000 ~ 0599

: Read Only

D-Reg.	PROCESS	FUNCTION	RESERVATION	ON/OFF SIGNAL	INNER SIGNAL	ALARM SIGNAL
	0	100	200	300	400	500
0		SET.PTNO	RESERVE			
1	NPV	COM.OPMODE	NOW.YEAR	T1.LSP	IS1.TYPE	AL1.OPMODE
2	NSP	FIX.TSP	NOW.MONTH	T1.MSP	IS1.BAND	AL2.OPMODE
3			NOW.DAY	T1.HSP	IS1.RH	AL3.OPMODE
4		OP.MODE	NOW.AMPM	T1.HDV	IS1.RL	AL4.OPMODE
5	HMVOUT	PWR.MODE	NOW.HOUR	T1.LDV	IS1.DYT	ALM1.TYPE
6	CMVOUT	SLOPE	NOW.MIN			ALM1.POINT
7	MVOUT		C.YEAR		IS2.TYPE	ALM1.H_POINT
8		FUZZY	C.MONTH	T2.LSP	IS2.BAND	ALM1.L_POINT
9	C.PIDNO	TIME.OP	C.DAY	T2.MSP	IS2.RH	ALM1.HYS
10	NOW.STS	TIME.OP_H	C.AMPM	T2.HSP	IS2.RL	ALM1.DYT
11	IS.STS	TIME.OP_M	C.HOUR	T2.HDV	IS2.DYT	
12	TS.STS	KEYLOCK	C.MIN	T2.LDV		ALM2.TYPE
13	ALM.STS		R.YEAR		IS3.TYPE	ALM2.POINT
14	ONOFF.STS	LIGHT.OFFTM	R.MONTH		IS3.BAND	ALM2.H_POINT
15	DOCTR.STS		R.DAY	T3.LSP	IS3.RH	ALM2.L_POINT
16	CTR.STS		R.AMPM	T3.MSP	IS3.RL	ALM2.HYS
17	USEROUT.STSL		R.HOUR	T3.HSP	IS3.DYT	ALM2.DYT
18	USEROUT.STSH		R.MIN	T3.HDV		
19	DI.DATA			T3.LDV	IS4.TYPE	ALM3.TYPE
20	ADERR.STS	RESTRICT_MAIN			IS4.BAND	ALM3.POINT
21	RUN.ACCTIME_H				IS4.RH	ALM3.H_POINT
22	RUN.ACCTIME_M			T4.LSP	IS4.RL	ALM3.L_POINT
23	RUN.ACCTIME_S			T4.MSP	IS4.DYT	ALM3.HYS
24	RUN.TIME_H			T4.HSP		ALM3.DYT
25	RUN.TIME_M			T4.HDV	IS5.TYPE	
26	RUN.TIME_S			T4.LDV	IS5.BAND	ALM4.TYPE
27	RUN.PTNO				IS5.RH	ALM4.POINT
28	RUN.SEGNO				IS5.RL	ALM4.H_POINT
29	NOW.PT.RPT	REC.OP		T5.LSP	IS5.DYT	ALM4.L_POINT
30	TOTAL.PT.RPT	REC.CYCLE		T5.MSP		ALM4.HYS
31	NOW.SEG.RPT			T5.HSP	IS6.TYPE	ALM4.DYT
32	TOTAL.SEG.RPT			T5.HDV	IS6.BAND	
33	NOW.SEGTIME_H			T5.LDV	IS6.RH	
34	NOW.SEGTIME_L				IS6.RL	
35	TOTAL.SEGTIME_H				IS6.DYT	
36	TOTAL.SEGTIME_L	AT		T6.LSP		
37				T6.MSP	IS7.TYPE	
38				T6.HSP	IS7.BAND	
39	PREV.TSP			T6.HDV	IS7.RH	
40	NOW.TSP	WAIT.USE		T6.LDV	IS7.RL	SA1.TYPE
41		WAIT_ZONE			IS7.DYT	SA1.POINT
42						SA1.H_POINT
43		WAIT_TIME			IS8.TYPE	SA1.L_POINT
44		WAIT.METHOD			IS8.BAND	SA1.HYS
45	SYS.STATUS				IS8.RH	SA1.DYT
46	LOGICAL.STATUS				IS8.RL	SA2.TYPE
47	SEGALM.STS	DANGER.DISPLAY			IS8.DYT	SA2.POINT
48						SA2.H_POINT
49		BUZ.ONOFF				SA2.L_POINT

D-Reg.	PROCESS	FUNCTION	RESERVATION	ON/OFF SIGNAL	INNER SIGNAL	ALARM SIGNAL
	0	100	200	300	400	500
50	USED PATTERN					SA2.HYS
51	USED SEGMENT					SA2.DYT
52	DP	UTAG_USING				SA3.TYPE
53		UTAG.NAME1				SA3.POINT
54		UTAG.NAME2				SA3.H_POINT
55		UTAG.NAME3				SA3.L_POINT
56						SA3.HYS
57						SA3.DYT
58						SA4.TYPE
59						SA4.POINT
60		USER KEY	TIME_VALID			SA4.H_POINT
61			START_YEAR			SA4.L_POINT
62			START_MON			SA4.HYS
63		UTAG_USING	START_DAY			SA4.DYT
64		UTAG.NAME1	START_HOUR			SA5.TYPE
65			START_MIN			SA5.POINT
66			END_YEAR			SA5.H_POINT
67			END_MON			SA5.L_POINT
68			END_DAY			SA5.HYS
69			END_HOUR			SA5.DYT
70			END_MIN			SA6.TYPE
71						SA6.POINT
72						SA6.H_POINT
73						SA6.L_POINT
74						SA6.HYS
75						SA6.DYT
76						SA7.TYPE
77						SA7.POINT
78						SA7.H_POINT
79						SA7.L_POINT
80						SA7.HYS
81						SA7.DYT
82						SA8.TYPE
83						SA8.POINT
84						SA8.H_POINT
85						SA8.L_POINT
86						SA8.HYS
87						SA8.DYT
88						
89						
90						
91						
92						
93						
94						
95						
96						
97						
98						
99						

D-Register 0600 ~ 1199

D-Reg.	TIME SIGNAL	PID	COMMUNICATION	INPUT	OUTPUT	DO CONFIG1
	600	700	800	900	1000	1100
0						
1	TS2DYTM_H	RP1	COM2.PROTOCOL	SENGP		IS1.RLY
2	TS2DYTM_L	RP2	COM2.BPS	SENTP	DIR	IS2.RLY
3	TS2KPTM_H	RP3	COM2.PARITY	UNIT	HCT	IS3.RLY
4	TS2KPTM_L	RP4	COM2.STOP.BIT	DP	HATG	IS4.RLY
5	TS3DYTM_H		COM2.DATA.LENG	TCSL	HPO	IS5.RLY
6	TS3DYTM_L	RHYS	COM2.ADDRESS	SOPN_SEL	CCT	IS6.RLY
7	TS3KPTM_H	RDEV	COM2.RESPONSE	INRH	CATG	IS7.RLY
8	TS3KPTM_L		COMM.LOCK	INRL	CPO	IS8.RLY
9	TS4DYTM_H	CMOD	COM4.BPS	BIAS	ARW	TS1.RLY
10	TS4DYTM_L		SYNC.MST	INFL		TS2.RLY
11	TS4KPTM_H	AT_POINT			UPOPR	TS3.RLY
12	TS4KPTM_L	AT_DISPLAY		INSH	DNOPR	TS4.RLY
13	TS5DYTM_H	PID.OPMODE		INSL		TS5.RLY
14	TS5DYTM_L	PID.APP				TS6.RLY
15	TS5KPTM_H				RETT	TS7.RLY
16	TS5KPTM_L			SPLMT.H	RETH	TS8.RLY
17	TS6DYTM_H	1.HP		SPLMT.L	RETL	ALM1.RLY
18	TS6DYTM_L	1.HI				ALM2.RLY
19	TS6KPTM_H	1.HD				ALM3.RLY
20	TS6KPTM_L	1.HOH				ALM4.RLY
21	TS7DYTM_H	1.OL				SA1.RLY
22	TS7DYTM_L	1.MR				SA2.RLY
23	TS7KPTM_H	1.HHYS				SA3.RLY
24	TS7KPTM_L	1.LHYS				SA4.RLY
25	TS8DYTM_H	2.HP				T1.RLY
26	TS8DYTM_L	2.HI				T1.DYT
27	TS8KPTM_H	2.HD				T2.RLY
28	TS8KPTM_L	2.HOH				T2.DYT
29	TS9DYTM_H	2.OL				T3.RLY
30	TS9DYTM_L	2.MR				T3.DYT
31	TS9KPTM_H	2.HHYS		BP1.DDV	OUT1.TYPE	T4.RLY
32	TS9KPTM_L	2.LHYS		BP2.DDV	OUT2.TYPE	T4.DYT
33	TS10DYTM_H	3.HP		BP3.DDV	OUT3.TYPE	T5.RLY
34	TS10DYTM_L	3.HI		BP4.DDV	OUT4.TYPE	T5.DYT
35	TS10KPTM_H	3.HD		BP5.DDV		T6.RLY
36	TS10KPTM_L	3.HOH		BP6.DDV		T6.DYT
37	TS11DYTM_H	3.OL		BP7.DDV	OUT1.MODE	T7.RLY
38	TS11DYTM_L	3.MR		BP8.DDV	OUT2.MODE	T7.DYT
39	TS11KPTM_H	3.HHYS		BP1.DPV	OUT3.MODE	DI1.RLY
40	TS11KPTM_L	3.LHYS		BP2.DPV	OUT4.MODE	DI2.RLY
41	TS12DYTM_H	4.HP		BP3.DPV		DI3.RLY
42	TS12DYTM_L	4.HI		BP4.DPV		DI4.RLY
43	TS12KPTM_H	4.HD		BP5.DPV		DI5.RLY
44	TS12KPTM_L	4.HOH		BP6.DPV		DI6.RLY
45	TS13DYTM_H	4.OL		BP7.DPV		DI7.RLY
46	TS13DYTM_L	4.MR		BP8.DPV		DI8.RLY
47	TS13KPTM_H	4.HHYS				DI9.RLY
48	TS13KPTM_L	4.LHYS				DI10.RLY
49	TS14DYTM_H	5.HP				DI11.RLY

D-Reg.	TIME SIGNAL	PID	COMMUNICATION	INPUT	OUTPUT	DO CONFIG1
	600	700	800	900	1000	1100
50	TS14DYTM_L	5.HI				DI12.RLY
51	TS14KPTM_H	5.HD				DI13.RLY
52	TS14KPTM_L	5.HOH				DI14.RLY
53	TS15DYTM_H	5.OL				DI15.RLY
54	TS15DYTM_L	5.MR				DI16.RLY
55	TS15KPTM_H	5.HHYS				USER.RLY1
56	TS15KPTM_L	5.LHYS				USER.RLY2
57	TS16DYTM_H	6.HP				USER.RLY3
58	TS16DYTM_L	6.HI				USER.RLY4
59	TS16KPTM_H	6.HD				USER.RLY5
60	TS16KPTM_L	6.HOH				USER.RLY6
61	TS17DYTM_H	6.OL				USER.RLY7
62	TS17DYTM_L	6.MR				USER.RLY8
63	TS17KPTM_H	6.HHYS				USER.RLY9
64	TS17KPTM_L	6.LHYS				USER.RLY10
65	TS18DYTM_H					USER.RLY11
66	TS18DYTM_L	1.CP	1.HOL			USER.RLY12
67	TS18KPTM_H	1.CI	2.HOL			USER.RLY_ON/OFF
68	TS18KPTM_L	1.CD	3.HOL			LOG. OUTRLY1
69	TS19DYTM_H	2.CP	4.HOL			LOG. SRCRLYa1
70	TS19DYTM_L	2.CI	5.HOL	UNITNAME_1		LOG. SRCRLYb1
71	TS19KPTM_H	2.CD	6.HOL	UNITNAME_2		LOG. OPERAND1
72	TS19KPTM_L	3.CP	1.COL			LOG. OUTRLY2
73	TS20DYTM_H	3.CI	2.COL			LOG. SRCRLYa2
74	TS20DYTM_L	3.CD	3.COL			LOG. SRCRLYb2
75	TS20KPTM_H	4.CP	4.COL			LOG. OPERAND2
76	TS20KPTM_L	4.CI	5.COL			LOG. OUTRLY3
77		4.CD	6.COL			LOG. SRCRLYa3
78		5.CP				LOG. SRCRLYb3
79		5.CI				LOG. OPERAND3
80		5.CD				LOG. OUTRLY4
81		6.CP				LOG. SRCRLYa4
82		6.CI				LOG. SRCRLYb4
83		6.CD				LOG. OPERAND4
84						LOG. OUTRLY5
85		1.DB				LOG. SRCRLYa5
86		2.DB				LOG. SRCRLYb5
87		3.DB				LOG. OPERAND5
88		4.DB				LOG. OUTRLY6
89		5.DB				LOG. SRCRLYa6
90		6.DB				LOG. SRCRLYb6
91						LOG. OPERAND6
92		HCHYS				LOG. OUTRLY7
93						LOG. SRCRLYa7
94						LOG. SRCRLYb7
95						LOG. OPERAND7
96						LOG. OUTRLY8
97						LOG. SRCRLYa8
98						LOG. SRCRLYb8
99						LOG. OPERAND8

D-Register 1200 ~ 1799

D-Reg.	DO CONFIG2	DI CONFIG1	DI CONFIG2	DI CONFIG3	INITIAL1	INITIAL2
	1200	1300	1400	1500	1600	1700
0						
1	RUN.RLY	D11.OP_MODE	D11.NAME1	D19.NAME1	LANGUAGE	LAMP_IS1
2	RUN.DYT	D12.OP_MODE	D11.NAME2	D19.NAME2		LAMP_IS2
3	SOPN.RLY	D13.OP_MODE	D11.NAME3	D19.NAME3	UKEY.USE	LAMP_IS3
4	SOPN.KPT	D14.OP_MODE	D11.NAME4	D19.NAME4	UKEY.KIND	LAMP_IS4
5	WAIT.RLY	BUZ.TIME	D11.NAME5	D19.NAME5		LAMP_IS5
6	WAIT.KPT	D1DET.TIME	D11.NAME6	D19.NAME6	UKEY.NAME1	LAMP_IS6
7	FIXTIMER.RLY		D11.NAME7	D19.NAME7	UKEY.NAME2	LAMP_IS7
8	FIXTIMER.DEV		D11.NAME8	D19.NAME8	UKEY.NAME3	LAMP_IS8
9	FIXTIMER.DLY	D11.OP	D11.NAME9	D19.NAME9	UKEY.NAME4	LAMP_TS1
10	FIXTIMER.OPT	D11.DVT	D11.NAME10	D19.NAME10		LAMP_TS2
11	UP.RLY	D12.OP	D11.NAME11	D19.NAME11	INFORM1.NAME1	LAMP_TS3
12	UP.DEV	D12.DVT	D11.NAME12	D19.NAME12	INFORM1.NAME2	LAMP_TS4
13	UP.DEVSEL	D13.OP	D12.NAME1	D110.NAME1	INFORM1.NAME3	LAMP_TS5
14	SOAK.RLY	D13.DVT	D12.NAME2	D110.NAME2	INFORM1.NAME4	LAMP_TS6
15	SOAK.KPT	D14.OP	D12.NAME3	D110.NAME3	INFORM1.NAME5	LAMP_TS7
16	DOWN.RLY	D14.DVT	D12.NAME4	D110.NAME4	INFORM1.NAME6	LAMP_TS8
17	DOWN.DEV	D15.OP	D12.NAME5	D110.NAME5	INFORM1.NAME7	LAMP_AL1
18	DOWN.DEVSEL	D15.DVT	D12.NAME6	D110.NAME6	INFORM1.NAME8	LAMP_AL2
19	1REF.RLY	D16.OP	D12.NAME7	D110.NAME7	INFORM1.NAME9	LAMP_AL3
20	1REF.DYT	D16.DVT	D12.NAME8	D110.NAME8	INFORM1.NAME10	LAMP_AL4
21	2REF.RLY	D17.OP	D12.NAME9	D110.NAME9	INFORM1.NAME11	LAMP_SAL1
22	2REF.DYT	D17.DVT	D12.NAME10	D110.NAME10	INFORM1.NAME12	LAMP_SAL2
23	ERROR.RLY	D18.OP	D12.NAME11	D110.NAME11	INFORM1.NAME13	LAMP_SAL3
24	ERROR.KPT	D18.DVT	D12.NAME12	D110.NAME12	INFORM2.NAME1	LAMP_SAL4
25	FEND.RLY	D19.OP	D13.NAME1	D111.NAME1	INFORM2.NAME2	LAMP_T1
26	FEND.DLT	D19.DVT	D13.NAME2	D111.NAME2	INFORM2.NAME3	LAMP_T2
27	FEND.OPT	D110.OP	D13.NAME3	D111.NAME3	INFORM2.NAME4	LAMP_T3
28	PTEND.RLY	D110.DVT	D13.NAME4	D111.NAME4	INFORM2.NAME5	LAMP_T4
29	PTEND.DLT	D111.OP	D13.NAME5	D111.NAME5	INFORM2.NAME6	LAMP_T5
30	PTEND.OPT	D111.DVT	D13.NAME6	D111.NAME6	INFORM2.NAME7	LAMP_T6
31	UKEY.RLY	D112.OP	D13.NAME7	D111.NAME7	INFORM2.NAME8	LAMP_T7
32	UKEY.OPT	D112.DVT	D13.NAME8	D111.NAME8	INFORM2.NAME9	LAMP_RUN
33		D113.OP	D13.NAME9	D111.NAME9	INFORM2.NAME10	LAMP_REF1
34		D113.DVT	D13.NAME10	D111.NAME10	INFORM2.NAME11	LAMP_REF2
35		D114.OP	D13.NAME11	D111.NAME11	INFORM2.NAME12	LAMP.LOG1
36		D114.DVT	D13.NAME12	D111.NAME12	INFORM2.NAME13	LAMP.LOG2
37		D115.OP	D14.NAME1	D112.NAME1	INFORM3.NAME1	LAMP.LOG3
38		D115.DVT	D14.NAME2	D112.NAME2	INFORM3.NAME2	LAMP.LOG4
39		D116.OP	D14.NAME3	D112.NAME3	INFORM3.NAME3	LAMP.LOG5
40		D116.DVT	D14.NAME4	D112.NAME4	INFORM3.NAME4	LAMP.LOG6
41			D14.NAME5	D112.NAME5	INFORM3.NAME5	LAMP.LOG7
42		D11.DETECT	D14.NAME6	D112.NAME6	INFORM3.NAME6	LAMP.LOG8
43		D12.DETECT	D14.NAME7	D112.NAME7	INFORM3.NAME7	LAMP_DI1
44		D13.DETECT	D14.NAME8	D112.NAME8	INFORM3.NAME8	LAMP_DI2
45		D14.DETECT	D14.NAME9	D112.NAME9	INFORM3.NAME9	LAMP_DI3
46		D15.DETECT	D14.NAME10	D112.NAME10	INFORM3.NAME10	LAMP_DI4
47		D16.DETECT	D14.NAME11	D112.NAME11	INFORM3.NAME11	LAMP_DI5
48		D17.DETECT	D14.NAME12	D112.NAME12	INFORM3.NAME12	LAMP_DI6
49		D18.DETECT	D15.NAME1	D113.NAME1	INFORM3.NAME13	LAMP_DI7

D-Reg.	DO CONFIG2	DI CONFIG1	DI CONFIG2	DI CONFIG3	INITIAL1	INITIAL2
	1200	1300	1400	1500	1600	1700
50		D19.DETECT	D15.NAME2	D113.NAME2		LAMP_D18
51		D110.DETECT	D15.NAME3	D113.NAME3		LAMP_D19
52		D111.DETECT	D15.NAME4	D113.NAME4		LAMP_D110
53		D112.DETECT	D15.NAME5	D113.NAME5		LAMP_D111
54		D113.DETECT	D15.NAME6	D113.NAME6		LAMP_D112
55		D114.DETECT	D15.NAME7	D113.NAME7		LAMP_D113
56		D115.DETECT	D15.NAME8	D113.NAME8		LAMP_D114
57		D116.DETECT	D15.NAME9	D113.NAME9		LAMP_D115
58		D19.DETECT	D15.NAME10	D113.NAME10		LAMP_D116
59		D110.DETECT	D15.NAME11	D113.NAME11		
60			D15.NAME12	D113.NAME12		
61			D16.NAME1	D114.NAME1		
62			D16.NAME2	D114.NAME2		
63			D16.NAME3	D114.NAME3		
64			D16.NAME4	D114.NAME4		
65			D16.NAME5	D114.NAME5		
66			D16.NAME6	D114.NAME6		
67			D16.NAME7	D114.NAME7		
68			D16.NAME8	D114.NAME8		
69			D16.NAME9	D114.NAME9		
70			D16.NAME10	D114.NAME10		
71			D16.NAME11	D114.NAME11		
72			D16.NAME12	D114.NAME12		
73			D17.NAME1	D115.NAME1		
74			D17.NAME2	D115.NAME2		
75			D17.NAME3	D115.NAME3		
76			D17.NAME4	D115.NAME4		
77			D17.NAME5	D115.NAME5		
78			D17.NAME6	D115.NAME6		
79			D17.NAME7	D115.NAME7		
80			D17.NAME8	D115.NAME8		
81			D17.NAME9	D115.NAME9		
82			D17.NAME10	D115.NAME10		
83			D17.NAME11	D115.NAME11		
84			D17.NAME12	D115.NAME12		
85			D18.NAME1	D116.NAME1		
86			D18.NAME2	D116.NAME2		
87			D18.NAME3	D116.NAME3		
88			D18.NAME4	D116.NAME4		
89			D18.NAME5	D116.NAME5		
90			D18.NAME6	D116.NAME6		
91			D18.NAME7	D116.NAME7		
92			D18.NAME8	D116.NAME8		
93			D18.NAME9	D116.NAME9		
94			D18.NAME10	D116.NAME10		
95			D18.NAME11	D116.NAME11		
96			D18.NAME12	D116.NAME12		
97						
98						
99						

D-Register 1800 ~ 2399

D-Reg.	INITIAL3	INITIAL4	PROGRAM	PATTERN INFO	FILE1	FILE2
	1800	1900	2000	2100	2200	2300
0						
1	LED1.NAME1	LED34.NAME1	COM_PTNO	NPT1	C.TSP1	C.SRTIME_H1
2	LED1.NAME2	LED34.NAME2	COM_SEGNO	NPT2	C.TSP2	C.SRTIME_H2
3	LED1.NAME3	LED34.NAME3	PTCOPY_START	NPT3	C.TSP3	C.SRTIME_H3
4	LED2.NAME1	LED35.NAME1	PTCOPY_END	NPT4	C.TSP4	C.SRTIME_H4
5	LED2.NAME2	LED35.NAME2	PTDEL_START	NPT5	C.TSP5	C.SRTIME_H5
6	LED2.NAME3	LED35.NAME3	PTDEL_END	NPT6	C.TSP6	C.SRTIME_H6
7	LED3.NAME1	LED36.NAME1	TRIGGER	NPT7	C.TSP7	C.SRTIME_H7
8	LED3.NAME2	LED36.NAME2	ANSWER	NPT8	C.TSP8	C.SRTIME_H8
9	LED3.NAME3	LED36.NAME3		NPT9	C.TSP9	C.SRTIME_H9
10	LED4.NAME1	LED37.NAME1		NPT10	C.TSP10	C.SRTIME_H10
11	LED4.NAME2	LED37.NAME2	PATTERN_NAME1	NPT11	C.TSP11	C.SRTIME_H11
12	LED4.NAME3	LED37.NAME3	PATTERN_NAME2	NPT12	C.TSP12	C.SRTIME_H12
13	LED5.NAME1	LED38.NAME1	PATTERN_NAME3	NPT13	C.TSP13	C.SRTIME_H13
14	LED5.NAME2	LED38.NAME2	PATTERN_NAME4	NPT14	C.TSP14	C.SRTIME_H14
15	LED5.NAME3	LED38.NAME3	PATTERN_NAME5	NPT15	C.TSP15	C.SRTIME_H15
16	LED6.NAME1	LED39.NAME1	PATTERN_NAME6	NPT16	C.TSP16	C.SRTIME_H16
17	LED6.NAME2	LED39.NAME2	PATTERN_NAME7	NPT17	C.TSP17	C.SRTIME_H17
18	LED6.NAME3	LED39.NAME3	PATTERN_NAME8	NPT18	C.TSP18	C.SRTIME_H18
19	LED7.NAME1	LED40.NAME1	PATTERN_NAME9	NPT19	C.TSP19	C.SRTIME_H19
20	LED7.NAME2	LED40.NAME2	PATTERN_NAME10	NPT20	C.TSP20	C.SRTIME_H20
21	LED7.NAME3	LED40.NAME3	PATTERN_NAME11	NPT21	C.TSP21	C.SRTIME_H21
22	LED8.NAME1	LED41.NAME1	PATTERN_NAME12	NPT22	C.TSP22	C.SRTIME_H22
23	LED8.NAME2	LED41.NAME2		NPT23	C.TSP23	C.SRTIME_H23
24	LED8.NAME3	LED41.NAME3		NPT24	C.TSP24	C.SRTIME_H24
25	LED9.NAME1	LED42.NAME1		NPT25	C.TSP25	C.SRTIME_H25
26	LED9.NAME2	LED42.NAME2	TSP	NPT26	C.TSP26	C.SRTIME_H26
27	LED9.NAME3	LED42.NAME3	SEG.TIME_H	NPT27	C.TSP27	C.SRTIME_H27
28	LED10.NAME1	LED43.NAME1	SEG.TIME_L	NPT28	C.TSP28	C.SRTIME_H28
29	LED10.NAME2	LED43.NAME2	TS1	NPT29	C.TSP29	C.SRTIME_H29
30	LED10.NAME3	LED43.NAME3	TS2	NPT30	C.TSP30	C.SRTIME_H30
31	LED11.NAME1	LED44.NAME1	TS3	NPT31	C.TSP31	C.SRTIME_H31
32	LED11.NAME2	LED44.NAME2	TS4	NPT32	C.TSP32	C.SRTIME_H32
33	LED11.NAME3	LED44.NAME3	TS5	NPT33	C.TSP33	C.SRTIME_H33
34	LED12.NAME1	LED45.NAME1	TS6	NPT34	C.TSP34	C.SRTIME_H34
35	LED12.NAME2	LED45.NAME2	TS7	NPT35	C.TSP35	C.SRTIME_H35
36	LED12.NAME3	LED45.NAME3	TS8/AUXOUT	NPT36	C.TSP36	C.SRTIME_H36
37	LED13.NAME1	LED46.NAME1	SEGAL1	NPT37	C.TSP37	C.SRTIME_H37
38	LED13.NAME2	LED46.NAME2	SEGAL2	NPT38	C.TSP38	C.SRTIME_H38
39	LED13.NAME3	LED46.NAME3	SEGAL3	NPT39	C.TSP39	C.SRTIME_H39
40	LED14.NAME1	LED47.NAME1	SEGAL4	NPT40	C.TSP40	C.SRTIME_H40
41	LED14.NAME2	LED47.NAME2	SEG_PID	NPT41	C.TSP41	C.SRTIME_H41
42	LED14.NAME3	LED47.NAME3		NPT42	C.TSP42	C.SRTIME_H42
43	LED15.NAME1	LED48.NAME1		NPT43	C.TSP43	C.SRTIME_H43
44	LED15.NAME2	LED48.NAME2		NPT44	C.TSP44	C.SRTIME_H44
45	LED15.NAME3	LED48.NAME3	START.CODE	NPT45	C.TSP45	C.SRTIME_H45
46	LED16.NAME1	LED49.NAME1	START.SP	NPT46	C.TSP46	C.SRTIME_H46
47	LED16.NAME2	LED49.NAME2		NPT47	C.TSP47	C.SRTIME_H47
48	LED16.NAME3	LED49.NAME3		NPT48	C.TSP48	C.SRTIME_H48
49	LED17.NAME1	LED50.NAME1		NPT49	C.TSP49	C.SRTIME_H49

D-Reg.	INITIAL3	INITIAL4	PROGRAM	PATTERN INFO	FILE1	FILE2
	1800	1900	2000	2100	2200	2300
50	LED17.NAME2	LED50.NAME2	PT.RPT	NPT50	C.TSP50	C.SRTIME_H50
51	LED17.NAME3	LED50.NAME3	PT.EMOD	NPT51	C.TSP51	C.SRTIME_H51
52	LED18.NAME1	LED51.NAME1	LINK.PT	NPT52	C.TSP52	C.SRTIME_H52
53	LED18.NAME2	LED51.NAME2		NPT53	C.TSP53	C.SRTIME_H53
54	LED18.NAME3	LED51.NAME3		NPT54	C.TSP54	C.SRTIME_H54
55	LED19.NAME1	LED52.NAME1		NPT55	C.TSP55	C.SRTIME_H55
56	LED19.NAME2	LED52.NAME2	SEG_RPT.S1	NPT56	C.TSP56	C.SRTIME_H56
57	LED19.NAME3	LED52.NAME3	SEG_RPT.E1	NPT57	C.TSP57	C.SRTIME_H57
58	LED20.NAME1	LED53.NAME1	SEG_RPT.C1	NPT58	C.TSP58	C.SRTIME_H58
59	LED20.NAME2	LED53.NAME2	SEG_RPT.S2	NPT59	C.TSP59	C.SRTIME_H59
60	LED20.NAME3	LED53.NAME3	SEG_RPT.E2	NPT60	C.TSP60	C.SRTIME_H60
61	LED21.NAME1	LED54.NAME1	SEG_RPT.C2	NPT61	C.TSP61	C.SRTIME_H61
62	LED21.NAME2	LED54.NAME2	SEG_RPT.S3	NPT62	C.TSP62	C.SRTIME_H62
63	LED21.NAME3	LED54.NAME3	SEG_RPT.E3	NPT63	C.TSP63	C.SRTIME_H63
64	LED22.NAME1	LED55.NAME1	SEG_RPT.C3	NPT64	C.TSP64	C.SRTIME_H64
65	LED22.NAME2	LED55.NAME2	SEG_RPT.S4	NPT65	C.TSP65	C.SRTIME_H65
66	LED22.NAME3	LED55.NAME3	SEG_RPT.E4	NPT66	C.TSP66	C.SRTIME_H66
67	LED23.NAME1	LED56.NAME1	SEG_RPT.C4	NPT67	C.TSP67	C.SRTIME_H67
68	LED23.NAME2	LED56.NAME2		NPT68	C.TSP68	C.SRTIME_H68
69	LED23.NAME3	LED56.NAME3		NPT69	C.TSP69	C.SRTIME_H69
70	LED24.NAME1	LED57.NAME1		NPT70	C.TSP70	C.SRTIME_H70
71	LED24.NAME2	LED57.NAME2		NPT71	C.TSP71	C.SRTIME_H71
72	LED24.NAME3	LED57.NAME3		NPT72	C.TSP72	C.SRTIME_H72
73	LED25.NAME1	LED58.NAME1		NPT73	C.TSP73	C.SRTIME_H73
74	LED25.NAME2	LED58.NAME2		NPT74	C.TSP74	C.SRTIME_H74
75	LED25.NAME3	LED58.NAME3		NPT75	C.TSP75	C.SRTIME_H75
76	LED26.NAME1	LED59.NAME1		NPT76	C.TSP76	C.SRTIME_H76
77	LED26.NAME2	LED59.NAME2		NPT77	C.TSP77	C.SRTIME_H77
78	LED26.NAME3	LED59.NAME3		NPT78	C.TSP78	C.SRTIME_H78
79	LED27.NAME1			NPT79	C.TSP79	C.SRTIME_H79
80	LED27.NAME2			NPT80	C.TSP80	C.SRTIME_H80
81	LED27.NAME3				C.TSP81	C.SRTIME_H81
82	LED28.NAME1				C.TSP82	C.SRTIME_H82
83	LED28.NAME2				C.TSP83	C.SRTIME_H83
84	LED28.NAME3				C.TSP84	C.SRTIME_H84
85	LED29.NAME1				C.TSP85	C.SRTIME_H85
86	LED29.NAME2				C.TSP86	C.SRTIME_H86
87	LED29.NAME3				C.TSP87	C.SRTIME_H87
88	LED30.NAME1				C.TSP88	C.SRTIME_H88
89	LED30.NAME2				C.TSP89	C.SRTIME_H89
90	LED30.NAME3				C.TSP90	C.SRTIME_H90
91	LED31.NAME1				C.TSP91	C.SRTIME_H91
92	LED31.NAME2				C.TSP92	C.SRTIME_H92
93	LED31.NAME3				C.TSP93	C.SRTIME_H93
94	LED32.NAME1				C.TSP94	C.SRTIME_H94
95	LED32.NAME2				C.TSP95	C.SRTIME_H95
96	LED32.NAME3				C.TSP96	C.SRTIME_H96
97	LED33.NAME1				C.TSP97	C.SRTIME_H97
98	LED33.NAME2				C.TSP98	C.SRTIME_H98
99	LED33.NAME3				C.TSP99	C.SRTIME_H99

D-Register 2400 ~ 2999

D-Reg.	FILE3	FILE4	FILE5	FILE6	FILE7	FILE8
	2400	2500	2600	2700	2800	2900
0						
1	C.SRTIME_L1	C.TS1_1	C.TS2_1	C.TS3_1	C.TS4_1	C.TS5_1
2	C.SRTIME_L2	C.TS1_2	C.TS2_2	C.TS3_2	C.TS4_2	C.TS5_2
3	C.SRTIME_L3	C.TS1_3	C.TS2_3	C.TS3_3	C.TS4_3	C.TS5_3
4	C.SRTIME_L4	C.TS1_4	C.TS2_4	C.TS3_4	C.TS4_4	C.TS5_4
5	C.SRTIME_L5	C.TS1_5	C.TS2_5	C.TS3_5	C.TS4_5	C.TS5_5
6	C.SRTIME_L6	C.TS1_6	C.TS2_6	C.TS3_6	C.TS4_6	C.TS5_6
7	C.SRTIME_L7	C.TS1_7	C.TS2_7	C.TS3_7	C.TS4_7	C.TS5_7
8	C.SRTIME_L8	C.TS1_8	C.TS2_8	C.TS3_8	C.TS4_8	C.TS5_8
9	C.SRTIME_L9	C.TS1_9	C.TS2_9	C.TS3_9	C.TS4_9	C.TS5_9
10	C.SRTIME_L10	C.TS1_10	C.TS2_10	C.TS3_10	C.TS4_10	C.TS5_10
11	C.SRTIME_L11	C.TS1_11	C.TS2_11	C.TS3_11	C.TS4_11	C.TS5_11
12	C.SRTIME_L12	C.TS1_12	C.TS2_12	C.TS3_12	C.TS4_12	C.TS5_12
13	C.SRTIME_L13	C.TS1_13	C.TS2_13	C.TS3_13	C.TS4_13	C.TS5_13
14	C.SRTIME_L14	C.TS1_14	C.TS2_14	C.TS3_14	C.TS4_14	C.TS5_14
15	C.SRTIME_L15	C.TS1_15	C.TS2_15	C.TS3_15	C.TS4_15	C.TS5_15
16	C.SRTIME_L16	C.TS1_16	C.TS2_16	C.TS3_16	C.TS4_16	C.TS5_16
17	C.SRTIME_L17	C.TS1_17	C.TS2_17	C.TS3_17	C.TS4_17	C.TS5_17
18	C.SRTIME_L18	C.TS1_18	C.TS2_18	C.TS3_18	C.TS4_18	C.TS5_18
19	C.SRTIME_L19	C.TS1_19	C.TS2_19	C.TS3_19	C.TS4_19	C.TS5_19
20	C.SRTIME_L20	C.TS1_20	C.TS2_20	C.TS3_20	C.TS4_20	C.TS5_20
21	C.SRTIME_L21	C.TS1_21	C.TS2_21	C.TS3_21	C.TS4_21	C.TS5_21
22	C.SRTIME_L22	C.TS1_22	C.TS2_22	C.TS3_22	C.TS4_22	C.TS5_22
23	C.SRTIME_L23	C.TS1_23	C.TS2_23	C.TS3_23	C.TS4_23	C.TS5_23
24	C.SRTIME_L24	C.TS1_24	C.TS2_24	C.TS3_24	C.TS4_24	C.TS5_24
25	C.SRTIME_L25	C.TS1_25	C.TS2_25	C.TS3_25	C.TS4_25	C.TS5_25
26	C.SRTIME_L26	C.TS1_26	C.TS2_26	C.TS3_26	C.TS4_26	C.TS5_26
27	C.SRTIME_L27	C.TS1_27	C.TS2_27	C.TS3_27	C.TS4_27	C.TS5_27
28	C.SRTIME_L28	C.TS1_28	C.TS2_28	C.TS3_28	C.TS4_28	C.TS5_28
29	C.SRTIME_L29	C.TS1_29	C.TS2_29	C.TS3_29	C.TS4_29	C.TS5_29
30	C.SRTIME_L30	C.TS1_30	C.TS2_30	C.TS3_30	C.TS4_30	C.TS5_30
31	C.SRTIME_L31	C.TS1_31	C.TS2_31	C.TS3_31	C.TS4_31	C.TS5_31
32	C.SRTIME_L32	C.TS1_32	C.TS2_32	C.TS3_32	C.TS4_32	C.TS5_32
33	C.SRTIME_L33	C.TS1_33	C.TS2_33	C.TS3_33	C.TS4_33	C.TS5_33
34	C.SRTIME_L34	C.TS1_34	C.TS2_34	C.TS3_34	C.TS4_34	C.TS5_34
35	C.SRTIME_L35	C.TS1_35	C.TS2_35	C.TS3_35	C.TS4_35	C.TS5_35
36	C.SRTIME_L36	C.TS1_36	C.TS2_36	C.TS3_36	C.TS4_36	C.TS5_36
37	C.SRTIME_L37	C.TS1_37	C.TS2_37	C.TS3_37	C.TS4_37	C.TS5_37
38	C.SRTIME_L38	C.TS1_38	C.TS2_38	C.TS3_38	C.TS4_38	C.TS5_38
39	C.SRTIME_L39	C.TS1_39	C.TS2_39	C.TS3_39	C.TS4_39	C.TS5_39
40	C.SRTIME_L40	C.TS1_40	C.TS2_40	C.TS3_40	C.TS4_40	C.TS5_40
41	C.SRTIME_L41	C.TS1_41	C.TS2_41	C.TS3_41	C.TS4_41	C.TS5_41
42	C.SRTIME_L42	C.TS1_42	C.TS2_42	C.TS3_42	C.TS4_42	C.TS5_42
43	C.SRTIME_L43	C.TS1_43	C.TS2_43	C.TS3_43	C.TS4_43	C.TS5_43
44	C.SRTIME_L44	C.TS1_44	C.TS2_44	C.TS3_44	C.TS4_44	C.TS5_44
45	C.SRTIME_L45	C.TS1_45	C.TS2_45	C.TS3_45	C.TS4_45	C.TS5_45
46	C.SRTIME_L46	C.TS1_46	C.TS2_46	C.TS3_46	C.TS4_46	C.TS5_46
47	C.SRTIME_L47	C.TS1_47	C.TS2_47	C.TS3_47	C.TS4_47	C.TS5_47
48	C.SRTIME_L48	C.TS1_48	C.TS2_48	C.TS3_48	C.TS4_48	C.TS5_48
49	C.SRTIME_L49	C.TS1_49	C.TS2_49	C.TS3_49	C.TS4_49	C.TS5_49

D-Reg.	FILE3	FILE4	FILE5	FILE6	FILE7	FILE8
	2400	2500	2600	2700	2800	2900
50	C.SRTIME_L50	C.TS1_50	C.TS2_50	C.TS3_50	C.TS4_50	C.TS5_50
51	C.SRTIME_L51	C.TS1_51	C.TS2_51	C.TS3_51	C.TS4_51	C.TS5_51
52	C.SRTIME_L52	C.TS1_52	C.TS2_52	C.TS3_52	C.TS4_52	C.TS5_52
53	C.SRTIME_L53	C.TS1_53	C.TS2_53	C.TS3_53	C.TS4_53	C.TS5_53
54	C.SRTIME_L54	C.TS1_54	C.TS2_54	C.TS3_54	C.TS4_54	C.TS5_54
55	C.SRTIME_L55	C.TS1_55	C.TS2_55	C.TS3_55	C.TS4_55	C.TS5_55
56	C.SRTIME_L56	C.TS1_56	C.TS2_56	C.TS3_56	C.TS4_56	C.TS5_56
57	C.SRTIME_L57	C.TS1_57	C.TS2_57	C.TS3_57	C.TS4_57	C.TS5_57
58	C.SRTIME_L58	C.TS1_58	C.TS2_58	C.TS3_58	C.TS4_58	C.TS5_58
59	C.SRTIME_L59	C.TS1_59	C.TS2_59	C.TS3_59	C.TS4_59	C.TS5_59
60	C.SRTIME_L60	C.TS1_60	C.TS2_60	C.TS3_60	C.TS4_60	C.TS5_60
61	C.SRTIME_L61	C.TS1_61	C.TS2_61	C.TS3_61	C.TS4_61	C.TS5_61
62	C.SRTIME_L62	C.TS1_62	C.TS2_62	C.TS3_62	C.TS4_62	C.TS5_62
63	C.SRTIME_L63	C.TS1_63	C.TS2_63	C.TS3_63	C.TS4_63	C.TS5_63
64	C.SRTIME_L64	C.TS1_64	C.TS2_64	C.TS3_64	C.TS4_64	C.TS5_64
65	C.SRTIME_L65	C.TS1_65	C.TS2_65	C.TS3_65	C.TS4_65	C.TS5_65
66	C.SRTIME_L66	C.TS1_66	C.TS2_66	C.TS3_66	C.TS4_66	C.TS5_66
67	C.SRTIME_L67	C.TS1_67	C.TS2_67	C.TS3_67	C.TS4_67	C.TS5_67
68	C.SRTIME_L68	C.TS1_68	C.TS2_68	C.TS3_68	C.TS4_68	C.TS5_68
69	C.SRTIME_L69	C.TS1_69	C.TS2_69	C.TS3_69	C.TS4_69	C.TS5_69
70	C.SRTIME_L70	C.TS1_70	C.TS2_70	C.TS3_70	C.TS4_70	C.TS5_70
71	C.SRTIME_L71	C.TS1_71	C.TS2_71	C.TS3_71	C.TS4_71	C.TS5_71
72	C.SRTIME_L72	C.TS1_72	C.TS2_72	C.TS3_72	C.TS4_72	C.TS5_72
73	C.SRTIME_L73	C.TS1_73	C.TS2_73	C.TS3_73	C.TS4_73	C.TS5_73
74	C.SRTIME_L74	C.TS1_74	C.TS2_74	C.TS3_74	C.TS4_74	C.TS5_74
75	C.SRTIME_L75	C.TS1_75	C.TS2_75	C.TS3_75	C.TS4_75	C.TS5_75
76	C.SRTIME_L76	C.TS1_76	C.TS2_76	C.TS3_76	C.TS4_76	C.TS5_76
77	C.SRTIME_L77	C.TS1_77	C.TS2_77	C.TS3_77	C.TS4_77	C.TS5_77
78	C.SRTIME_L78	C.TS1_78	C.TS2_78	C.TS3_78	C.TS4_78	C.TS5_78
79	C.SRTIME_L79	C.TS1_79	C.TS2_79	C.TS3_79	C.TS4_79	C.TS5_79
80	C.SRTIME_L80	C.TS1_80	C.TS2_80	C.TS3_80	C.TS4_80	C.TS5_80
81	C.SRTIME_L81	C.TS1_81	C.TS2_81	C.TS3_81	C.TS4_81	C.TS5_81
82	C.SRTIME_L82	C.TS1_82	C.TS2_82	C.TS3_82	C.TS4_82	C.TS5_82
83	C.SRTIME_L83	C.TS1_83	C.TS2_83	C.TS3_83	C.TS4_83	C.TS5_83
84	C.SRTIME_L84	C.TS1_84	C.TS2_84	C.TS3_84	C.TS4_84	C.TS5_84
85	C.SRTIME_L85	C.TS1_85	C.TS2_85	C.TS3_85	C.TS4_85	C.TS5_85
86	C.SRTIME_L86	C.TS1_86	C.TS2_86	C.TS3_86	C.TS4_86	C.TS5_86
87	C.SRTIME_L87	C.TS1_87	C.TS2_87	C.TS3_87	C.TS4_87	C.TS5_87
88	C.SRTIME_L88	C.TS1_88	C.TS2_88	C.TS3_88	C.TS4_88	C.TS5_88
89	C.SRTIME_L89	C.TS1_89	C.TS2_89	C.TS3_89	C.TS4_89	C.TS5_89
90	C.SRTIME_L90	C.TS1_90	C.TS2_90	C.TS3_90	C.TS4_90	C.TS5_90
91	C.SRTIME_L91	C.TS1_91	C.TS2_91	C.TS3_91	C.TS4_91	C.TS5_91
92	C.SRTIME_L92	C.TS1_92	C.TS2_92	C.TS3_92	C.TS4_92	C.TS5_92
93	C.SRTIME_L93	C.TS1_93	C.TS2_93	C.TS3_93	C.TS4_93	C.TS5_93
94	C.SRTIME_L94	C.TS1_94	C.TS2_94	C.TS3_94	C.TS4_94	C.TS5_94
95	C.SRTIME_L95	C.TS1_95	C.TS2_95	C.TS3_95	C.TS4_95	C.TS5_95
96	C.SRTIME_L96	C.TS1_96	C.TS2_96	C.TS3_96	C.TS4_96	C.TS5_96
97	C.SRTIME_L97	C.TS1_97	C.TS2_97	C.TS3_97	C.TS4_97	C.TS5_97
98	C.SRTIME_L98	C.TS1_98	C.TS2_98	C.TS3_98	C.TS4_98	C.TS5_98
99	C.SRTIME_L99	C.TS1_99	C.TS2_99	C.TS3_99	C.TS4_99	C.TS5_99

D-Register 3000 ~ 3599

D-Reg.	FILE8	FILE9	FILE10	FILE11	FILE12	FILE13
	3000	3100	3200	3300	3400	3500
0						
1	C.TS6_1	C.TS7_1	C.TS8_1	C.SEGAL1_1	C.SEGAL2_1	C.SEGAL3_1
2	C.TS6_2	C.TS7_2	C.TS8_2	C.SEGAL1_2	C.SEGAL2_2	C.SEGAL3_2
3	C.TS6_3	C.TS7_3	C.TS8_3	C.SEGAL1_3	C.SEGAL2_3	C.SEGAL3_3
4	C.TS6_4	C.TS7_4	C.TS8_4	C.SEGAL1_4	C.SEGAL2_4	C.SEGAL3_4
5	C.TS6_5	C.TS7_5	C.TS8_5	C.SEGAL1_5	C.SEGAL2_5	C.SEGAL3_5
6	C.TS6_6	C.TS7_6	C.TS8_6	C.SEGAL1_6	C.SEGAL2_6	C.SEGAL3_6
7	C.TS6_7	C.TS7_7	C.TS8_7	C.SEGAL1_7	C.SEGAL2_7	C.SEGAL3_7
8	C.TS6_8	C.TS7_8	C.TS8_8	C.SEGAL1_8	C.SEGAL2_8	C.SEGAL3_8
9	C.TS6_9	C.TS7_9	C.TS8_9	C.SEGAL1_9	C.SEGAL2_9	C.SEGAL3_9
10	C.TS6_10	C.TS7_10	C.TS8_10	C.SEGAL1_10	C.SEGAL2_10	C.SEGAL3_10
11	C.TS6_11	C.TS7_11	C.TS8_11	C.SEGAL1_11	C.SEGAL2_11	C.SEGAL3_11
12	C.TS6_12	C.TS7_12	C.TS8_12	C.SEGAL1_12	C.SEGAL2_12	C.SEGAL3_12
13	C.TS6_13	C.TS7_13	C.TS8_13	C.SEGAL1_13	C.SEGAL2_13	C.SEGAL3_13
14	C.TS6_14	C.TS7_14	C.TS8_14	C.SEGAL1_14	C.SEGAL2_14	C.SEGAL3_14
15	C.TS6_15	C.TS7_15	C.TS8_15	C.SEGAL1_15	C.SEGAL2_15	C.SEGAL3_15
16	C.TS6_16	C.TS7_16	C.TS8_16	C.SEGAL1_16	C.SEGAL2_16	C.SEGAL3_16
17	C.TS6_17	C.TS7_17	C.TS8_17	C.SEGAL1_17	C.SEGAL2_17	C.SEGAL3_17
18	C.TS6_18	C.TS7_18	C.TS8_18	C.SEGAL1_18	C.SEGAL2_18	C.SEGAL3_18
19	C.TS6_19	C.TS7_19	C.TS8_19	C.SEGAL1_19	C.SEGAL2_19	C.SEGAL3_19
20	C.TS6_20	C.TS7_20	C.TS8_20	C.SEGAL1_20	C.SEGAL2_20	C.SEGAL3_20
21	C.TS6_21	C.TS7_21	C.TS8_21	C.SEGAL1_21	C.SEGAL2_21	C.SEGAL3_21
22	C.TS6_22	C.TS7_22	C.TS8_22	C.SEGAL1_22	C.SEGAL2_22	C.SEGAL3_22
23	C.TS6_23	C.TS7_23	C.TS8_23	C.SEGAL1_23	C.SEGAL2_23	C.SEGAL3_23
24	C.TS6_24	C.TS7_24	C.TS8_24	C.SEGAL1_24	C.SEGAL2_24	C.SEGAL3_24
25	C.TS6_25	C.TS7_25	C.TS8_25	C.SEGAL1_25	C.SEGAL2_25	C.SEGAL3_25
26	C.TS6_26	C.TS7_26	C.TS8_26	C.SEGAL1_26	C.SEGAL2_26	C.SEGAL3_26
27	C.TS6_27	C.TS7_27	C.TS8_27	C.SEGAL1_27	C.SEGAL2_27	C.SEGAL3_27
28	C.TS6_28	C.TS7_28	C.TS8_28	C.SEGAL1_28	C.SEGAL2_28	C.SEGAL3_28
29	C.TS6_29	C.TS7_29	C.TS8_29	C.SEGAL1_29	C.SEGAL2_29	C.SEGAL3_29
30	C.TS6_30	C.TS7_30	C.TS8_30	C.SEGAL1_30	C.SEGAL2_30	C.SEGAL3_30
31	C.TS6_31	C.TS7_31	C.TS8_31	C.SEGAL1_31	C.SEGAL2_31	C.SEGAL3_31
32	C.TS6_32	C.TS7_32	C.TS8_32	C.SEGAL1_32	C.SEGAL2_32	C.SEGAL3_32
33	C.TS6_33	C.TS7_33	C.TS8_33	C.SEGAL1_33	C.SEGAL2_33	C.SEGAL3_33
34	C.TS6_34	C.TS7_34	C.TS8_34	C.SEGAL1_34	C.SEGAL2_34	C.SEGAL3_34
35	C.TS6_35	C.TS7_35	C.TS8_35	C.SEGAL1_35	C.SEGAL2_35	C.SEGAL3_35
36	C.TS6_36	C.TS7_36	C.TS8_36	C.SEGAL1_36	C.SEGAL2_36	C.SEGAL3_36
37	C.TS6_37	C.TS7_37	C.TS8_37	C.SEGAL1_37	C.SEGAL2_37	C.SEGAL3_37
38	C.TS6_38	C.TS7_38	C.TS8_38	C.SEGAL1_38	C.SEGAL2_38	C.SEGAL3_38
39	C.TS6_39	C.TS7_39	C.TS8_39	C.SEGAL1_39	C.SEGAL2_39	C.SEGAL3_39
40	C.TS6_40	C.TS7_40	C.TS8_40	C.SEGAL1_40	C.SEGAL2_40	C.SEGAL3_40
41	C.TS6_41	C.TS7_41	C.TS8_41	C.SEGAL1_41	C.SEGAL2_41	C.SEGAL3_41
42	C.TS6_42	C.TS7_42	C.TS8_42	C.SEGAL1_42	C.SEGAL2_42	C.SEGAL3_42
43	C.TS6_43	C.TS7_43	C.TS8_43	C.SEGAL1_43	C.SEGAL2_43	C.SEGAL3_43
44	C.TS6_44	C.TS7_44	C.TS8_44	C.SEGAL1_44	C.SEGAL2_44	C.SEGAL3_44
45	C.TS6_45	C.TS7_45	C.TS8_45	C.SEGAL1_45	C.SEGAL2_45	C.SEGAL3_45
46	C.TS6_46	C.TS7_46	C.TS8_46	C.SEGAL1_46	C.SEGAL2_46	C.SEGAL3_46
47	C.TS6_47	C.TS7_47	C.TS8_47	C.SEGAL1_47	C.SEGAL2_47	C.SEGAL3_47
48	C.TS6_48	C.TS7_48	C.TS8_48	C.SEGAL1_48	C.SEGAL2_48	C.SEGAL3_48
49	C.TS6_49	C.TS7_49	C.TS8_49	C.SEGAL1_49	C.SEGAL2_49	C.SEGAL3_49

D-Reg.	FILE8	FILE9	FILE10	FILE11	FILE12	FILE13
	3000	3100	3200	3300	3400	3500
50	C.TS6_50	C.TS7_50	C.TS8_50	C.SEGAL1_50	C.SEGAL2_50	C.SEGAL3_50
51	C.TS6_51	C.TS7_51	C.TS8_51	C.SEGAL1_51	C.SEGAL2_51	C.SEGAL3_51
52	C.TS6_52	C.TS7_52	C.TS8_52	C.SEGAL1_52	C.SEGAL2_52	C.SEGAL3_52
53	C.TS6_53	C.TS7_53	C.TS8_53	C.SEGAL1_53	C.SEGAL2_53	C.SEGAL3_53
54	C.TS6_54	C.TS7_54	C.TS8_54	C.SEGAL1_54	C.SEGAL2_54	C.SEGAL3_54
55	C.TS6_55	C.TS7_55	C.TS8_55	C.SEGAL1_55	C.SEGAL2_55	C.SEGAL3_55
56	C.TS6_56	C.TS7_56	C.TS8_56	C.SEGAL1_56	C.SEGAL2_56	C.SEGAL3_56
57	C.TS6_57	C.TS7_57	C.TS8_57	C.SEGAL1_57	C.SEGAL2_57	C.SEGAL3_57
58	C.TS6_58	C.TS7_58	C.TS8_58	C.SEGAL1_58	C.SEGAL2_58	C.SEGAL3_58
59	C.TS6_59	C.TS7_59	C.TS8_59	C.SEGAL1_59	C.SEGAL2_59	C.SEGAL3_59
60	C.TS6_60	C.TS7_60	C.TS8_60	C.SEGAL1_60	C.SEGAL2_60	C.SEGAL3_60
61	C.TS6_61	C.TS7_61	C.TS8_61	C.SEGAL1_61	C.SEGAL2_61	C.SEGAL3_61
62	C.TS6_62	C.TS7_62	C.TS8_62	C.SEGAL1_62	C.SEGAL2_62	C.SEGAL3_62
63	C.TS6_63	C.TS7_63	C.TS8_63	C.SEGAL1_63	C.SEGAL2_63	C.SEGAL3_63
64	C.TS6_64	C.TS7_64	C.TS8_64	C.SEGAL1_64	C.SEGAL2_64	C.SEGAL3_64
65	C.TS6_65	C.TS7_65	C.TS8_65	C.SEGAL1_65	C.SEGAL2_65	C.SEGAL3_65
66	C.TS6_66	C.TS7_66	C.TS8_66	C.SEGAL1_66	C.SEGAL2_66	C.SEGAL3_66
67	C.TS6_67	C.TS7_67	C.TS8_67	C.SEGAL1_67	C.SEGAL2_67	C.SEGAL3_67
68	C.TS6_68	C.TS7_68	C.TS8_68	C.SEGAL1_68	C.SEGAL2_68	C.SEGAL3_68
69	C.TS6_69	C.TS7_69	C.TS8_69	C.SEGAL1_69	C.SEGAL2_69	C.SEGAL3_69
70	C.TS6_70	C.TS7_70	C.TS8_70	C.SEGAL1_70	C.SEGAL2_70	C.SEGAL3_70
71	C.TS6_71	C.TS7_71	C.TS8_71	C.SEGAL1_71	C.SEGAL2_71	C.SEGAL3_71
72	C.TS6_72	C.TS7_72	C.TS8_72	C.SEGAL1_72	C.SEGAL2_72	C.SEGAL3_72
73	C.TS6_73	C.TS7_73	C.TS8_73	C.SEGAL1_73	C.SEGAL2_73	C.SEGAL3_73
74	C.TS6_74	C.TS7_74	C.TS8_74	C.SEGAL1_74	C.SEGAL2_74	C.SEGAL3_74
75	C.TS6_75	C.TS7_75	C.TS8_75	C.SEGAL1_75	C.SEGAL2_75	C.SEGAL3_75
76	C.TS6_76	C.TS7_76	C.TS8_76	C.SEGAL1_76	C.SEGAL2_76	C.SEGAL3_76
77	C.TS6_77	C.TS7_77	C.TS8_77	C.SEGAL1_77	C.SEGAL2_77	C.SEGAL3_77
78	C.TS6_78	C.TS7_78	C.TS8_78	C.SEGAL1_78	C.SEGAL2_78	C.SEGAL3_78
79	C.TS6_79	C.TS7_79	C.TS8_79	C.SEGAL1_79	C.SEGAL2_79	C.SEGAL3_79
80	C.TS6_80	C.TS7_80	C.TS8_80	C.SEGAL1_80	C.SEGAL2_80	C.SEGAL3_80
81	C.TS6_81	C.TS7_81	C.TS8_81	C.SEGAL1_81	C.SEGAL2_81	C.SEGAL3_81
82	C.TS6_82	C.TS7_82	C.TS8_82	C.SEGAL1_82	C.SEGAL2_82	C.SEGAL3_82
83	C.TS6_83	C.TS7_83	C.TS8_83	C.SEGAL1_83	C.SEGAL2_83	C.SEGAL3_83
84	C.TS6_84	C.TS7_84	C.TS8_84	C.SEGAL1_84	C.SEGAL2_84	C.SEGAL3_84
85	C.TS6_85	C.TS7_85	C.TS8_85	C.SEGAL1_85	C.SEGAL2_85	C.SEGAL3_85
86	C.TS6_86	C.TS7_86	C.TS8_86	C.SEGAL1_86	C.SEGAL2_86	C.SEGAL3_86
87	C.TS6_87	C.TS7_87	C.TS8_87	C.SEGAL1_87	C.SEGAL2_87	C.SEGAL3_87
88	C.TS6_88	C.TS7_88	C.TS8_88	C.SEGAL1_88	C.SEGAL2_88	C.SEGAL3_88
89	C.TS6_89	C.TS7_89	C.TS8_89	C.SEGAL1_89	C.SEGAL2_89	C.SEGAL3_89
90	C.TS6_90	C.TS7_90	C.TS8_90	C.SEGAL1_90	C.SEGAL2_90	C.SEGAL3_90
91	C.TS6_91	C.TS7_91	C.TS8_91	C.SEGAL1_91	C.SEGAL2_91	C.SEGAL3_91
92	C.TS6_92	C.TS7_92	C.TS8_92	C.SEGAL1_92	C.SEGAL2_92	C.SEGAL3_92
93	C.TS6_93	C.TS7_93	C.TS8_93	C.SEGAL1_93	C.SEGAL2_93	C.SEGAL3_93
94	C.TS6_94	C.TS7_94	C.TS8_94	C.SEGAL1_94	C.SEGAL2_94	C.SEGAL3_94
95	C.TS6_95	C.TS7_95	C.TS8_95	C.SEGAL1_95	C.SEGAL2_95	C.SEGAL3_95
96	C.TS6_96	C.TS7_96	C.TS8_96	C.SEGAL1_96	C.SEGAL2_96	C.SEGAL3_96
97	C.TS6_97	C.TS7_97	C.TS8_97	C.SEGAL1_97	C.SEGAL2_97	C.SEGAL3_97
98	C.TS6_98	C.TS7_98	C.TS8_98	C.SEGAL1_98	C.SEGAL2_98	C.SEGAL3_98
99	C.TS6_99	C.TS7_99	C.TS8_99	C.SEGAL1_99	C.SEGAL2_99	C.SEGAL3_99

D-Register 3600 ~ 4199

D-Reg.	FILE14	FILE15	LOGIC SIG1	LOGIC SIG2	RESERVED	RESERVED
	3600	3700	3800	3900	4000	4100
0						
1	C.SEGAL4_1	C.SEGPID_1	LOG1_SIGNAL1	LOG7_SIGNAL1		
2	C.SEGAL4_2	C.SEGPID_2	LOG1_ACT1	LOG7_ACT1		
3	C.SEGAL4_3	C.SEGPID_3	LOG1_DYT1	LOG7_DYT1		
4	C.SEGAL4_4	C.SEGPID_4	LOG1_SIGNAL2	LOG7_SIGNAL2		
5	C.SEGAL4_5	C.SEGPID_5	LOG1_ACT2	LOG7_ACT2		
6	C.SEGAL4_6	C.SEGPID_6	LOG1_DYT2	LOG7_DYT2		
7	C.SEGAL4_7	C.SEGPID_7	LOG1_SIGNAL3	LOG7_SIGNAL3		
8	C.SEGAL4_8	C.SEGPID_8	LOG1_ACT3	LOG7_ACT3		
9	C.SEGAL4_9	C.SEGPID_9	LOG1_DYT3	LOG7_DYT3		
10	C.SEGAL4_10	C.SEGPID_10	LOG1_SIGNAL4	LOG7_SIGNAL4		
11	C.SEGAL4_11	C.SEGPID_11	LOG1_ACT4	LOG7_ACT4		
12	C.SEGAL4_12	C.SEGPID_12	LOG1_DYT4	LOG7_DYT4		
13	C.SEGAL4_13	C.SEGPID_13	LOG1_OPERAND1	LOG7_OPERAND1		
14	C.SEGAL4_14	C.SEGPID_14	LOG1_OPERAND2	LOG7_OPERAND2		
15	C.SEGAL4_15	C.SEGPID_15	LOG1_OPERAND3	LOG7_OPERAND3		
16	C.SEGAL4_16	C.SEGPID_16	LOG2_SIGNAL1	LOG8_SIGNAL1		
17	C.SEGAL4_17	C.SEGPID_17	LOG2_ACT1	LOG8_ACT1		
18	C.SEGAL4_18	C.SEGPID_18	LOG2_DYT1	LOG8_DYT1		
19	C.SEGAL4_19	C.SEGPID_19	LOG2_SIGNAL2	LOG8_SIGNAL2		
20	C.SEGAL4_20	C.SEGPID_20	LOG2_ACT2	LOG8_ACT2		
21	C.SEGAL4_21	C.SEGPID_21	LOG2_DYT2	LOG8_DYT2		
22	C.SEGAL4_22	C.SEGPID_22	LOG2_SIGNAL3	LOG8_SIGNAL3		
23	C.SEGAL4_23	C.SEGPID_23	LOG2_ACT3	LOG8_ACT3		
24	C.SEGAL4_24	C.SEGPID_24	LOG2_DYT3	LOG8_DYT3		
25	C.SEGAL4_25	C.SEGPID_25	LOG2_SIGNAL4	LOG8_SIGNAL4		
26	C.SEGAL4_26	C.SEGPID_26	LOG2_ACT4	LOG8_ACT4		
27	C.SEGAL4_27	C.SEGPID_27	LOG2_DYT4	LOG8_DYT4		
28	C.SEGAL4_28	C.SEGPID_28	LOG2_OPERAND1	LOG8_OPERAND1		
29	C.SEGAL4_29	C.SEGPID_29	LOG2_OPERAND2	LOG8_OPERAND2		
30	C.SEGAL4_30	C.SEGPID_30	LOG2_OPERAND3	LOG8_OPERAND3		
31	C.SEGAL4_31	C.SEGPID_31	LOG3_SIGNAL1			
32	C.SEGAL4_32	C.SEGPID_32	LOG3_ACT1			
33	C.SEGAL4_33	C.SEGPID_33	LOG3_DYT1			
34	C.SEGAL4_34	C.SEGPID_34	LOG3_SIGNAL2			
35	C.SEGAL4_35	C.SEGPID_35	LOG3_ACT2			
36	C.SEGAL4_36	C.SEGPID_36	LOG3_DYT2			
37	C.SEGAL4_37	C.SEGPID_37	LOG3_SIGNAL3			
38	C.SEGAL4_38	C.SEGPID_38	LOG3_ACT3			
39	C.SEGAL4_39	C.SEGPID_39	LOG3_DYT3			
40	C.SEGAL4_40	C.SEGPID_40	LOG3_SIGNAL4			
41	C.SEGAL4_41	C.SEGPID_41	LOG3_ACT4			
42	C.SEGAL4_42	C.SEGPID_42	LOG3_DYT4			
43	C.SEGAL4_43	C.SEGPID_43	LOG3_OPERAND1			
44	C.SEGAL4_44	C.SEGPID_44	LOG3_OPERAND2			
45	C.SEGAL4_45	C.SEGPID_45	LOG3_OPERAND3			
46	C.SEGAL4_46	C.SEGPID_46	LOG4_SIGNAL1			
47	C.SEGAL4_47	C.SEGPID_47	LOG4_ACT1			
48	C.SEGAL4_48	C.SEGPID_48	LOG4_DYT1			
49	C.SEGAL4_49	C.SEGPID_49	LOG4_SIGNAL2			

D-Reg.	FILE14	FILE15	LOGIC SIG1	LOGIC SIG2	RESERVED	RESERVED
	3600	3700	3800	3900	4000	4100
50	C.SEGAL4_50	C.SEGPID_50	LOG4_ACT2			
51	C.SEGAL4_51	C.SEGPID_51	LOG4_DYT2			
52	C.SEGAL4_52	C.SEGPID_52	LOG4_SIGNAL3			
53	C.SEGAL4_53	C.SEGPID_53	LOG4_ACT3			
54	C.SEGAL4_54	C.SEGPID_54	LOG4_DYT3			
55	C.SEGAL4_55	C.SEGPID_55	LOG4_SIGNAL4			
56	C.SEGAL4_56	C.SEGPID_56	LOG4_ACT4			
57	C.SEGAL4_57	C.SEGPID_57	LOG4_DYT4			
58	C.SEGAL4_58	C.SEGPID_58	LOG4_OPERAND1			
59	C.SEGAL4_59	C.SEGPID_59	LOG4_OPERAND2			
60	C.SEGAL4_60	C.SEGPID_60	LOG4_OPERAND3			
61	C.SEGAL4_61	C.SEGPID_61	LOG5_SIGNAL1			
62	C.SEGAL4_62	C.SEGPID_62	LOG5_ACT1			
63	C.SEGAL4_63	C.SEGPID_63	LOG5_DYT1			
64	C.SEGAL4_64	C.SEGPID_64	LOG5_SIGNAL2			
65	C.SEGAL4_65	C.SEGPID_65	LOG5_ACT2			
66	C.SEGAL4_66	C.SEGPID_66	LOG5_DYT2			
67	C.SEGAL4_67	C.SEGPID_67	LOG5_SIGNAL3			
68	C.SEGAL4_68	C.SEGPID_68	LOG5_ACT3			
69	C.SEGAL4_69	C.SEGPID_69	LOG5_DYT3			
70	C.SEGAL4_70	C.SEGPID_70	LOG5_SIGNAL4			
71	C.SEGAL4_71	C.SEGPID_71	LOG5_ACT4			
72	C.SEGAL4_72	C.SEGPID_72	LOG5_DYT4			
73	C.SEGAL4_73	C.SEGPID_73	LOG5_OPERAND1			
74	C.SEGAL4_74	C.SEGPID_74	LOG5_OPERAND2			
75	C.SEGAL4_75	C.SEGPID_75	LOG5_OPERAND3			
76	C.SEGAL4_76	C.SEGPID_76	LOG6_SIGNAL1			
77	C.SEGAL4_77	C.SEGPID_77	LOG6_ACT1			
78	C.SEGAL4_78	C.SEGPID_78	LOG6_DYT1			
79	C.SEGAL4_79	C.SEGPID_79	LOG6_SIGNAL2			
80	C.SEGAL4_80	C.SEGPID_80	LOG6_ACT2			
81	C.SEGAL4_81	C.SEGPID_81	LOG6_DYT2			
82	C.SEGAL4_82	C.SEGPID_82	LOG6_SIGNAL3			
83	C.SEGAL4_83	C.SEGPID_83	LOG6_ACT3			
84	C.SEGAL4_84	C.SEGPID_84	LOG6_DYT3			
85	C.SEGAL4_85	C.SEGPID_85	LOG6_SIGNAL4			
86	C.SEGAL4_86	C.SEGPID_86	LOG6_ACT4			
87	C.SEGAL4_87	C.SEGPID_87	LOG6_DYT4			
88	C.SEGAL4_88	C.SEGPID_88	LOG6_OPERAND1			
89	C.SEGAL4_89	C.SEGPID_89	LOG6_OPERAND2			
90	C.SEGAL4_90	C.SEGPID_90	LOG6_OPERAND3			
91	C.SEGAL4_91	C.SEGPID_91				
92	C.SEGAL4_92	C.SEGPID_92				
93	C.SEGAL4_93	C.SEGPID_93				
94	C.SEGAL4_94	C.SEGPID_94				
95	C.SEGAL4_95	C.SEGPID_95				
96	C.SEGAL4_96	C.SEGPID_96				
97	C.SEGAL4_97	C.SEGPID_97				
98	C.SEGAL4_98	C.SEGPID_98				
99	C.SEGAL4_99	C.SEGPID_99				



SAMWONTECH CO., LTD.

202-703, Buchon Techno-Park,
Yakdae-dong, Wonmi-gu, Buchon-si
Gyeonggi-do, Korea 420-773
TEL : +82-32-326-9120
FAX : +82-32-326-9119
Website: <http://www.samwontech.com>
e-mail : webmater@samwontech.com

Further information contact SAMWONTECH